

---

## Lime Microsystems Limited

Surrey Tech Centre Occam Road  
The Surrey Research Park Guildford Surrey,  
GU2 7YG  
UNITED KINGDOM



Tel: +44 (0) 1428-653-335  
Fax: +44 (0) 1483-683-481  
e-mail: [enquiries@limemicro.com](mailto:enquiries@limemicro.com)

# **LMS6002 – Wide Band Multi Standard Radio Chip in 0.18um BiCMOS**

## ***- Programming and Calibration Guide -***

Chip version: LMS6002D  
Chip revision: r2  
Document version: 1.1  
Document revision: 1  
Last modified: 03/05/2012 13:17:00



# Contents

<b>1. Serial Port Interface</b> .....	<b>1</b>
1.1 Description .....	1
<b>2. LMS6002Dr2 Memory Map Description</b> .....	<b>3</b>
2.1 LMS6002Dr2 Memory Map .....	3
2.2 Top Level Configuration .....	4
2.3 TX/RX PLL Configuration .....	7
2.4 TX LPF Modules Configuration .....	10
2.5 RX LPF, ADC and DAC Modules Configuration .....	12
2.6 TX RF Modules Configuration .....	16
2.7 RX VGA2 Configuration .....	19
2.8 RX FE Modules Configuration .....	21
<b>3. Control Block Diagrams</b> .....	<b>25</b>
3.1 SPI READ/WRITE Pseudo Code .....	25
3.2 Loopback and Bypass Modes.....	26
3.3 Envelop and Pick Detector Multiplexer .....	27
3.4 TX/RX PLL.....	27
3.4.1 FREQSEL.....	28
3.4.2 Integer and Fractional Part of the Divider.....	28
3.4.3 VCO Capacitor, Icp and Ioff Selection .....	29
3.4.4 PLL Control.....	31
3.5 TX/RX LPF .....	32
3.6 TX RF.....	32
3.7 RX VGA2.....	33
3.8 RX FE.....	34
<b>4. Calibration Flow Charts</b> .....	<b>35</b>
4.1 General DC Calibration Procedure .....	36
4.2 DC Offset Calibration of LPF Tuning Module .....	37
4.3 TX/RX LPF DC Offset Calibration .....	38
4.4 RXVGA2 DC Offset Calibration .....	39
4.5 LPF Bandwidth Tuning.....	40
4.6 VCOCAP Code Selection Algorithm.....	41
4.7 Auto Calibration Summary .....	41
4.8 TX LO Leakage Calibration.....	42
4.9 TX Single Side Band Calibration.....	43
4.10 Correction and Measurement Functions Implemented in BB .....	44
4.10.1 Applying IQ Phase and Gain Offsets to Baseband Signals.....	44
4.10.2 Measuring TX Error Using RX Signal.....	45
4.10.3 Measuring RX I and Q DC Levels .....	45

# Revision History

## **Version 1.0r0**

*Released: Mar 16, 2010*

Initial version constructed from new SPI and old 6002D programming guide documents.

## **Version 1.0r1**

*Released: Apr 15, 2010*

Unnoticed change in 0x5F register documented

## **Version 1.1r0**

*Released: Oct 27, 2010*

FREQSEL table updated. Calibration diagrams updated. VCOCAP selection algorithm added.

## **Version 1.1r1**

*Released: Oct 28, 2010*

Diagram 4.3 corrected.

# 1

## Serial Port Interface

### 1.1 Description

The functionality of LMS6002 transceiver is fully controlled by a set of internal registers which can be accessed through a serial port interface. Both write and read operations are supported. The serial port can be configured to run in 3 or 4 wire mode with the following pins used:

- SEN serial port enable, active low;
- SCLK serial clock;
- SDIO serial data in/out in 3 wire mode, serial data input in 4 wire mode;
- SDO serial data out in 4 wire mode, don't care in 3 wire mode.

Serial port key features:

- 16 serial clock cycles are required to complete write operation;
- 16 serial clock cycles are required to complete read operation;
- Multiple write/read operations are possible without toggling serial enable signal.

All configuration registers are 8-bit wide. Write/read sequence consists of 8-bit instruction followed by 8-bit data to write or read. MSB of the instruction bit stream is used as SPI command where  $CMD = 1$  for write and  $CMD = 0$  for read. Next 3 bits represent block address since LMS6002 configuration registers are divided into eight logical blocks as shown in Table 1. Remaining 4 bits of the instruction are used to address particular registers within the block as described in Section 2. Use address values from the tables.

Write/read cycle waveforms are shown in Figure 1, Figure 1.2 and Figure 1.3. Note that write operation is the same for both 3-wire and 4-wire modes. Although not shown in the figures, multiple byte write/read is possible by repeating instruction/data sequence while keeping SEN low.

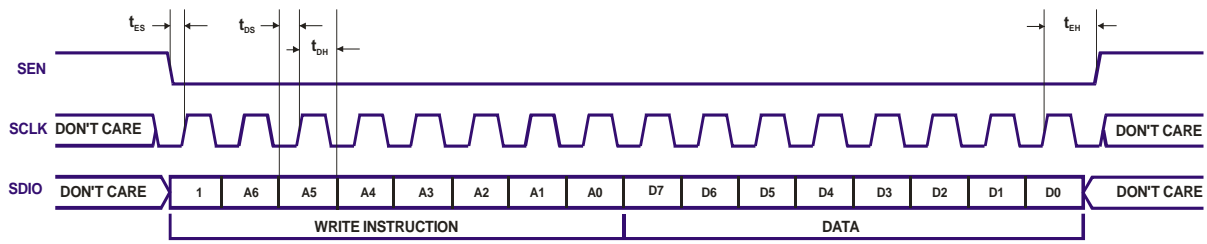

Figure 1.1: SPI write cycle, 3-wire and 4-wire modes

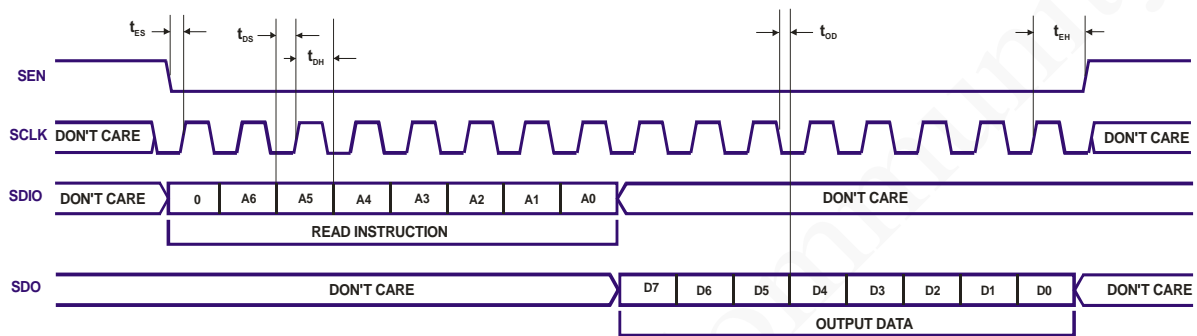

Figure 1.2: SPI read cycle, 4-wire mode (default)

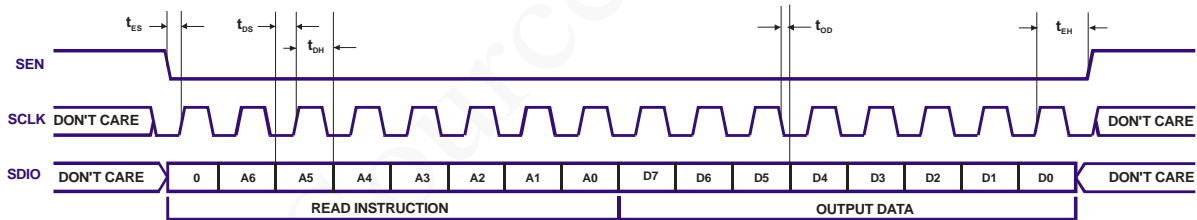

Figure 1.3: SPI read cycle, 3-wire mode

# 2

## LMS6002Dr2 Memory Map Description

### 2.1 LMS6002Dr2 Memory Map

Table 1: LMS6002Dr2 memory map

Address (7 bits)	Description
x000:xxxx	Top level configuration (as in Table 2, Table 3, Table 4, Table 5)
x001:xxxx	TX PLL configuration (as in Table 6, Table 7, Table 8)
x010:xxxx	RX PLL configuration (as in Table 6, Table 7, Table 8)
x011:xxxx	TX LPF modules configuration (as in Table 9, Table 10)
x100:xxxx	TX RF modules configuration (as in Table 15, Table 17, Table 17)
x101:xxxx	RX LPF, DAC/ADC modules configuration (as in Table 9, Table 10, Table 103, Table 104)
x110:xxxx	RX VGA2 configuration (as in Table 18, Table 19)
x111:xxxx	RX FE modules configuration (as in Table 20, Table 21, Table 22)

## 2.2 Top Level Configuration

Table 2: Top level configuration memory map (user mode)

Address (7 bits)	Bits	Description
0x00	7-6 5-0	Not used DC_REGVAL[5:0]: Value from DC calibration module selected by DC_ADDR. <b>Read Only.</b>
0x01	7-5 4-2 1 0	RCCAL_LPFICAL[2:0]: Value of the cal_core block in the LPF which calibrates the RC time constant. It should be read by software to set the value of the TIA feedback cap (CFB_RXFE_TIA). DC_LOCK[2:0]: Lock pattern register. Locked, when register value is not "000" nor "111". DC_CLBR_DONE : indicates calibration status. 1 – calibration in progress; 0 – calibration is done. DC_UD: Value from DC module comparator, selected by DC_ADDR 1 – Count Up; 0 – Count Down. <b>Read Only.</b>
0x02	7-6 5-0	Not used DC_CNTVAL[5:0] : Value to load into selected (by DC_ADDR) DC calibration module. <b>Default: 00011111</b>
0x03	7-6 5 4 3 2-0	Not used DC_START_CLBR: Start calibration command of the module, selected by DC_ADDR 1 – Start Calibration; 0 – Deactivate Start Calibration command. <b>(default)</b> DC_LOAD: Load value from DC_CNTVAL to module, selected by DC_ADDR 1 – Load Value; 0 – Deactivate Load Value command. <b>(default)</b> DC_SRESET: resets all DC Calibration modules 1 – Reset inactive; <b>(default)</b> 0 – Reset active. DC_ADDR[2:0]: Active calibration module address. 000 – LPF tuning module. 001-111 – Not used. <b>Default: 00001000</b>
0x04	7-4 3-0	VER[3:0]: Chip version REV[3:0]: Chip revision <b>Read only.</b> <b>Default: 00100010</b>
0x05	7 6 5 4 3 2 1 0	DECODE: 0 – decode control signals <b>(default)</b> 1 – use control signals from test mode registers. Not used SRESET: DSM soft reset 0 – reset state 1 – inactive <b>(default)</b> EN: Top modules enable EN =0 – Top modules powered down EN =1 – Top modules enabled <b>(default)</b> STXEN: Soft transmit enable STXEN=0 – Transmitter powered down <b>(default)</b> STXEN=1 – Transmitter enabled SRXEN: Soft receive enable SRXEN=0 – Receiver powered down <b>(default)</b> SRXEN=1 – Receiver enabled TFWMODE: Serial port mode TFWMODE=0 – three wire mode TFWMODE=1 – four wire mode <b>(default)</b> Not used <b>Default: 00110010</b>



Table 3: Top level configuration memory map (user mode) (continued)

Address (7 bits)	Bits	Description																																		
0x06	7-4 3 2 1 0	<p>Not used</p> <p>CLKSEL_LPFICAL: Select the clock for LPF tuning module                      0 – 40 MHz clock generated from TX PLL output                      1 – use PLL reference clock <b>(default)</b></p> <p>PD_CLKLPFICAL: Power down on chip LPF tuning clock generation block                      0 – powered up                      1 – powered down <b>(default)</b></p> <p>ENF_EN_CAL_LPFICAL: Enables the enforce mode. Passes FORCE_CODE_CAL_LPFICAL to RCCAL_LPFICAL.                      0 – enforce mode disabled <b>(default)</b>                      1 – enforce mode enabled</p> <p>RST_CAL_LPFICAL: Reset signal used at the beginning of calibration cycle. Reset signal needs to be longer than 100ns.                      0 – normal state                      1 – reset state <b>(default)</b></p> <p><b>Default: 00001101</b></p>																																		
0x07	7 6-4 3-0	<p>EN_CAL_LPFICAL: Enable signal. If =1--&gt; the block is enabled. Should be enabled only during the RC calibration algorithm running.                      0 – Block disabled <b>(default)</b>                      1 – Block enabled</p> <p>FORCE_CODE_CAL_LPFICAL[2:0]: Input code coming from software. Will be passed to the output if ENF_EN_CAL_LPFICAL=1.                      000 <b>(default)</b></p> <p>BWC_LPFICAL[3:0]: LPF bandwidth control (Set this code to RXLPF BWC if RXLPF and TXLPF have different cut-off frequencies).</p> <table border="0"> <thead> <tr> <th>code</th> <th>Bandwidth [MHz]</th> </tr> </thead> <tbody> <tr><td>0000</td><td>14 <b>(default)</b></td></tr> <tr><td>0001</td><td>10</td></tr> <tr><td>0010</td><td>7</td></tr> <tr><td>0011</td><td>6</td></tr> <tr><td>0100</td><td>5</td></tr> <tr><td>0101</td><td>4.375</td></tr> <tr><td>0110</td><td>3.5</td></tr> <tr><td>0111</td><td>3</td></tr> <tr><td>1000</td><td>2.75</td></tr> <tr><td>1001</td><td>2.5</td></tr> <tr><td>1010</td><td>1.92</td></tr> <tr><td>1011</td><td>1.5</td></tr> <tr><td>1100</td><td>1.375</td></tr> <tr><td>1101</td><td>1.25</td></tr> <tr><td>1110</td><td>0.875</td></tr> <tr><td>1111</td><td>0.75</td></tr> </tbody> </table> <p><b>Default: 00000000</b></p>	code	Bandwidth [MHz]	0000	14 <b>(default)</b>	0001	10	0010	7	0011	6	0100	5	0101	4.375	0110	3.5	0111	3	1000	2.75	1001	2.5	1010	1.92	1011	1.5	1100	1.375	1101	1.25	1110	0.875	1111	0.75
code	Bandwidth [MHz]																																			
0000	14 <b>(default)</b>																																			
0001	10																																			
0010	7																																			
0011	6																																			
0100	5																																			
0101	4.375																																			
0110	3.5																																			
0111	3																																			
1000	2.75																																			
1001	2.5																																			
1010	1.92																																			
1011	1.5																																			
1100	1.375																																			
1101	1.25																																			
1110	0.875																																			
1111	0.75																																			
0x08	7 6 5 4 3-0	<p>Reserved                      0 – <b>default</b> value.</p> <p>LBEN_LPFIN: BB loopback enable. If =1, TX BB loopback signal is connected to RXLPF input. If enabled, RXTIA should be disabled (powered down)                      0 – <b>default</b> value.</p> <p>LBEN_VGA2IN: BB loopback enable. If =1, TX BB loopback signal is connected to RXVGA2 input. If enabled, LPF should be disabled (powered down).                      0 – <b>default</b> value.</p> <p>LBEN_OPIN: BB loopback enable. If =1, TX BB loopback signal is connected to the RX output pins. If enabled, RXLPF and RXVGA2 should be disabled (powered down)                      0 – <b>default</b> value.</p> <p>LBRFEN[3:0]: RF loop back control. When activated, LNAs should be disabled (powered down).</p> <table border="0"> <tbody> <tr><td>0</td><td>RF loopback disabled <b>(default)</b></td></tr> <tr><td>1</td><td>TXMIX output connected to LNA1 path</td></tr> <tr><td>2</td><td>TXMIX output connected to LNA2 path</td></tr> <tr><td>3</td><td>TXMIX output connected to LNA3 path</td></tr> <tr><td>4-15</td><td>Reserved. Not valid for settings.</td></tr> </tbody> </table> <p><b>Default: 00000000</b></p>	0	RF loopback disabled <b>(default)</b>	1	TXMIX output connected to LNA1 path	2	TXMIX output connected to LNA2 path	3	TXMIX output connected to LNA3 path	4-15	Reserved. Not valid for settings.																								
0	RF loopback disabled <b>(default)</b>																																			
1	TXMIX output connected to LNA1 path																																			
2	TXMIX output connected to LNA2 path																																			
3	TXMIX output connected to LNA3 path																																			
4-15	Reserved. Not valid for settings.																																			

Table 4: Top level configuration memory map (user mode) (continued)

Address (7 bits)	Bits	Description
0x09	7	RXOUTSW: RX out/ADC in high-Z switch control 0 – switch open (RX output/ADC input chip pins disconnected) <b>(default)</b> 1 – switch closed, RXVGA2 should be powered off first
	6–0	CLK_EN[6:0]: Clock distribution control
	6	CLK_EN [6]: 1 – PLLCLKOUT enabled <b>(default)</b> 0 – PLLCLKOUT disabled
	5	CLK_EN [5]: 1 – LPF CAL clock enabled 0 – LPF CAL clock disabled <b>(default)</b>
	4	CLK_EN [4]: 1 – Rx VGA2 DCCAL clock enabled 0 – Rx VGA2 DCCAL clock disabled <b>(default)</b>
	3	CLK_EN [3]: 1 – Rx LPF DCCAL clock enabled 0 – Rx LPF DCCAL clock disabled <b>(default)</b>
	2	CLK_EN [2]: 1 – Rx DSM SPI clock enabled 0 – Rx DSM SPI clock disabled <b>(default)</b>
	1	CLK_EN [1]: 1 – Tx LPF SPI DCCAL clock enabled 0 – Tx LPF SPI DCCAL clock disabled <b>(default)</b>
	0	CLK_EN [0]: 1 – Tx DSM SPI clock enabled 0 – Tx DSM SPI clock disabled <b>(default)</b> <b>Default: 01000000</b>
0x0A	7-2	Not used
	1	FDDTDD: Frequency/Time division duplexing selection 0 – FDD mode <b>(default)</b> 1 – TDD mode
	0	TDDMOD: TDD mode selection if FDDTDD=1 0 – TDD Transmit mode <b>(default)</b> 1 – TDD Receive mode <b>Default: 00000000</b>

Table 5: Top level configuration memory map (user mode)

Address (7 bits)	Bits	Description
0x0B	7–5	Not used
	4	PDXCOBUF: XCO buffer power down 0 – buffer powered up <b>(default)</b> 1 – buffer powered down
	3	SLFBXCOBUF: XCO buffer self biasing control 0 – self biasing disabled 1 – self biasing enabled <b>(default)</b>
	2	BYPXCOBUF: XCO buffer bypass 0 – buffer active <b>(default)</b> 1 – buffer bypassed
	1–0	PD[1:0]: Power down control for top modules: PD[1]: 1 – PD_DCOREF_LPF CAL powered down 0 – PD_DCOREF_LPF CAL powered up <b>(default)</b> PD[0]: 1 – RF loop back switch powered up 0 – RF loop back switch powered down <b>(default)</b> <b>Default: 00001000</b>
0x0E	5-0	SPARE0[7:0]: Spare configuration register. <b>Default: 00000000</b>
0x0F	7–0	SPARE1[7:0]: Spare configuration register. <b>Default: 00000000</b>



Table 7: TX/RX PLL configuration memory map (user mode) (continued)

Address (7 bits)	Bits	Description
Tx: 0x16, Rx: 0x26	7 6 5 4-0	<p>EN_PFD_UP: Enable PFD UP pulses 0 – disabled 1 – enabled <b>(default)</b></p> <p>OEN_TSTD_SX: 0 – Test signal output buffer disabled <b>(default)</b> 1 – Test signal output buffer enabled</p> <p>PASSEN_TSTOD_SD: 0 – Test signal pass disabled <b>(default)</b> 1 – Test signal pass enabled</p> <p>ICHP[4:0]: Charge pump current. Binary coded, LSB = 100uA: 00000 – 0uA 00001 – 100uA ... 11000 – 2400uA ... – 2400 uA <b>Default:</b> “10001100”, ICHP = 1.2mA</p>
Tx: 0x17, Rx: 0x27	7 6 5 4-0	<p>BYPVCOREG: Bypass VCO regulator 0 – not bypassed 1 – regulator bypassed <b>(default)</b></p> <p>PDVCOREG: VCO regulator power down. 0 – regulator powered up 1 – regulator powered down <b>(default)</b></p> <p>FSTVCOBG: VCO regulator band gap settling time control. Shorts the resistor in band gap to speed up charging for faster response. After the initial charge up, it should be disabled. 1 – resistor shorted <b>(default)</b> 0 – switch open</p> <p>OFFUP[4:0]: Charge pump UP offset current. Binary coded, LSB = 10uA: 00000 – 0uA 00001 – 10uA ... 11000 – 240uA ... – 240uA <b>Default:</b> “11100000” = 0mA</p>
Tx: 0x18, Rx: 0x28	7-5 4-0	<p>VOVCOREG[3:1]: VCO regulator output voltage control, 3 MSBs. LSB=100mV, VOVCOREG[3:0] coded as below 0000 – 1.4V, min output ... 0101 – 1.9V <b>(default)</b> ... 1100 – 2.6V, max output 1101, 1110, 1111, not valid codes</p> <p>OFFDOWN[4:0]: Charge pump DOWN offset current. Binary coded, LSB = 10uA: 00000 – 0uA 00001 – 10uA ... 11000 – 240uA ... – 240uA <b>Default:</b> “01000000” = 0mA</p>
Tx: 0x19, Rx: 0x29	7 6 5-0	<p>VOVCOREG[0]: VCO regulator output voltage control, LSB Not used</p> <p>VCOCAP[5:0]: Switch capacitance programming. Binary coded. 000000 (max capacitance, min frequency) 010100 <b>(default)</b> 111111 (min capacitance, max frequency) <b>Default:</b> “10010100”, VCOCAP=20</p>

Table 8: TX/RX PLL configuration memory map (test mode)

Address (7 bits)	Bits	Description
Tx: 0x1A, Rx: 0x2A	7 6 5-0	VTUNE_H ( <b>Read Only</b> ): Value from Vtune comparator VTUNE_L ( <b>Read Only</b> ): Value from Vtune comparator Reserved 000011 – ( <b>default</b> ) <b>Default:</b> "00000011"
Tx: 0x1B, Rx: 0x2B	7-4 3 2 1 0	Reserved 0111 – ( <b>default</b> ) PD_VCOCOMP_SX: VCO Comparator Enable 0 – enabled (powered up) ( <b>default</b> ) 1 – disabled (powered down) Reserved 1 – ( <b>default</b> ) Reserved 1 – ( <b>default</b> ) Reserved 0 – ( <b>default</b> ) <b>Default:</b> "01110110", A value = 0, (N=130).
Tx: 0x1C, Rx: 0x2C	7-0	Reserved <b>Default:</b> "00111000"
Tx: 0x1D, Rx: 0x2	7-0	Reserved <b>Read only</b>
Tx: 0x1E, Rx: 0x2E	7-0	Reserved <b>Read only</b>
Tx: 0x1F, Rx: 0x2F	7-0	Reserved <b>Read only</b>



Table 10: TX LPF configuration memory map (test mode)

Address (7 bits)	Bits	Description
0x36	7	TX_DACBUF_PD: TX data DAC buffers power down 0 – enabled ( <b>default</b> ) 1 – powered Down
	6–4	RCCAL_LPF[2:0]: Calibration value, coming from TRX_LPF_CAL module. 011 – ( <b>default</b> )
	3	PD_DCOCMP_LPF: Power down for DC offset comparator in the DC offset cancellation block. Should be powered up only when DC offset cancellation algorithm is running. 1 – Powered Down 0 – Enabled ( <b>default</b> )
	2	PD_DCODAC_LPF: Power down for the DAC in the DC offset cancellation block. 1 – Powered Down 0 – Enabled ( <b>default</b> )
	1	PD_DCOREF_LPF: Power down signal for the dc_ref_con3 block. 1 – Powered Down 0 – Enabled ( <b>default</b> )
	0	PD_FIL_LPF: Power down for the filter. 1 – Powered Down 0 – Enabled ( <b>default</b> ) <b>Default:</b> 00110000
	0x3E	7-0
0x3F	7–0	SPARE1[7:0]: Spare configuration register. <b>Default:</b> 00000000





Table 12: RX LPF configuration memory map (user mode) (continued)

Address (7 bits)	Bits	Description
0x56	7	Not Used
	6–4	RCCAL_LPF[2:0]: Calibration value, coming from TRX_LPF_CAL module. 011 – <b>(default)</b>
	3	PD_DCOCMP_LPF: Power down for DC offset comparator in the DC offset cancellation block. Should be powered up only when DC offset cancellation algorithm is running. 1 – Powered Down 0 – Enabled <b>(default)</b>
	2	PD_DCODAC_LPF: Power down for the DAC in the DC offset cancellation block. 1 – Powered Down 0 – Enabled <b>(default)</b>
	1	PD_DCOREF_LPF: Power down signal for the dc_ref_con3 block. 1 – Powered Down 0 – Enabled <b>(default)</b>
	0	PD_FIL_LPF: Power down for the filter. 1 – Powered Down 0 – Enabled <b>(default)</b> <b>Default: 00110000</b>
0x57	7	EN_ADC_DAC : ADC/DAC modules enable 0 – ADC/DAC modules powered down 1 – ADC/DAC modules enabled <b>(default)</b>
	6	DECODE: 0 – decode ADC/DAC enable signals <b>(default)</b> 1 – use ADC/DAC enable signals from MISC_CTRL[4:0] register.
	5–3	TX_CTRL1[6:4]. DAC Internal Output Load Resistor Control Bits 111 – 50 Ohms 110 – 100 Ohms 101 – 66 Ohms 100 – 200 Ohms 011 – 66 Ohms 010 – 200 Ohms <b>(default)</b> 001 – 100 Ohms 000 – Open Circuit
	2	TX_CTRL1[3]. DAC Reference Current Resistor: 1 – External <b>(default)</b> 0 – Internal
	1–0	TX_CTRL1[1:0]. DAC Full Scale Output Current Control (single-ended): 11 – Iout FS=5ma 10 – Iout FS=2.5ma 01 – Iout FS=10ma 00 – Iout FS=5ma <b>(default)</b> <b>Default: 10010100</b>
		<b>Default: 10010100</b>
0x58	7–6	RX_CTRL1[7:6]. Reference bias resistor adjust: 11 – 15uA 10 – 10uA 01 – 40uA 00 – 20uA <b>(default)</b>
	5–4	RX_CTRL1[5:4]. Reference bias UP: 11 – 2.5X 10 – 2.0X 01 – 1.5X 00 – 1.0X <b>(default)</b>
	3–0	RX_CTRL1[3:0]. Reference bias DOWN: 1111 – Min Bias ... 0000 – Max Bias <b>(default)</b> <b>Default: 00000000</b>

Table 13 RX LPF configuration memory map (user mode) (continued)

Address (7 bits)	Bits	Description
0x59	7 6–5 4–3 2–1 0	<p>Not Used</p> <p>RX_CTRL2[7:6]. Reference Gain Adjust: 11 – 1.25V 10 – 1.00V 01 – 1.75V 00 – 1.50V <b>(default)</b></p> <p>RX_CTRL2[5:4]. Common Mode Adjust: 11 – 790mV 10 – 700mV 01 – 960mV 00 – 875mV <b>(default)</b></p> <p>RX_CTRL2[3:2]. Reference Buffer Boost: 11 – 2.5X 10 – 2.0X 01 – 1.5X 00 – 1.0X <b>(default)</b></p> <p>RX_CTRL2[0]. ADC Input Buffer Disable: 1 – Disabled <b>(default)</b> 0 – Enabled <b>Default: 00000001</b></p>
0x5A	7 6 5 4 3 2 1–0	<p>MISC_CTRL[9]. Rx Fsync Polarity, frame start: 1 – 1 0 – 0 <b>(default)</b></p> <p>MISC_CTRL[8]. Rx Interleave Mode: 1 – Q,I 0 – I,Q <b>(default)</b></p> <p>MISC_CTRL[7]. Dac Clk Edge Polarity: 1 – negative <b>(default)</b> 0 – positive</p> <p>MISC_CTRL[6]. Tx Fsync Polarity, frame start: 1 – 1 0 – 0 <b>(default)</b></p> <p>MISC_CTRL[5]. Tx Interleave Mode: 1 – Q,I 0 – I,Q <b>(default)</b></p> <p>RX_CTRL3[7]. ADC Sampling Phase Select: 1 – falling edge 0 – rising edge <b>(default)</b></p> <p>RX_CTRL3[1:0]. Clock Non-Overlap Adjust: 11 – +300ps 10 – +150ps 01 – +450ps 00 – Nominal <b>(default)</b> <b>Default: 00100000</b></p>
0x5B	7–6 5–4 3–2 1–0	<p>RX_CTRL4[7:6] ADC bias resistor adjust: 11 – 15uA 10 – 10uA 01 – 40uA 00 – 20uA <b>(default)</b></p> <p>RX_CTRL4[5:4]. Main bias DOWN: 11 – Min Bias 10 – 01 – 00 – Nominal <b>(default)</b></p> <p>RX_CTRL4[3:2]. ADC Amp1 stage1 bias UP: 11 – 15uA 10 – 10uA 01 – 40uA 00 – 20uA <b>(default)</b></p> <p>RX_CTRL4[1:0]. ADC Amp2-4 stage1 bias UP: 11 – 15uA 10 – 10uA 01 – 40uA 00 – 20uA <b>(default)</b> <b>Default: 00000000</b></p>

Table 14 RX LPF configuration memory map (user/test mode) (continued)

Address (7 bits)	Bits	Description
0x5C	7-6	RX_CTRL5[7:6] ADC Amp1 stage2 bias UP: 11 – 15uA 10 – 10uA 01 – 40uA 00 – 20uA <b>(default)</b>
	5-4	RX_CTRL5[5:4]. ADC Amp2-4 stage2 bias UP: 11 – 15uA 10 – 10uA 01 – 40uA 00 – 20uA <b>(default)</b>
	3-2	RX_CTRL5[3:2]. Quantizer bias UP: 11 – 15uA 10 – 10uA 01 – 40uA 00 – 20uA <b>(default)</b>
	1-0	RX_CTRL5[1:0]. Input Buffer bias UP: 11 – 15uA 10 – 10uA 01 – 40uA 00 – 20uA <b>(default)</b> <b>Default: 00000000</b>
0x5D	7-4	REF_CTRL0[7:4]. Bandgap Temperature Coefficient Control: 0111 – Max 0000 – Nominal <b>(default)</b> 1000 – Min
	3-0	REF_CTRL0[3:0]. Bandgap Gain Control: 0111 – Max 0000 – Nominal <b>(default)</b> 1000 – Min <b>Default: 00000000</b>
0x5E	7-6	REF_CTRL1[7:6]. Reference Amps bias adjust 11 – 15uA 10 – 10uA 01 – 40uA 00 – 20uA <b>(default)</b>
	5-4	REF_CTRL1[5:4]. Reference Amps bias UP: 11 – 2.5X 10 – 2.0X 01 – 1.5X 00 – 1.0X <b>(default)</b>
	3-0	REF_CTRL1[3:0]. Reference Amps bias DOWN: 1111 – Min Bias ... 0000 – Max Bias <b>(default)</b> <b>Default: 00000000</b>
0x5F	7-5	SPARE00[7:5]: Spare configuration bits. 000 – <b>(default)</b>
	4	MISC_CTRL[4]. Enable DAC: 1 – Enable <b>(default)</b> 0 – Off
	3	MISC_CTRL[3]. Enable ADC1 (I Channel): 1 – Enable <b>(default)</b> 0 – Off
	2	MISC_CTRL[2]. Enable ADC2 (Q Channel): 1 – Enable <b>(default)</b> 0 – Off
	1	MISC_CTRL[1]. Enable ADC reference: 1 – Enable <b>(default)</b> 0 – Off
	0	MISC_CTRL[0]. Enable master reference: 1 – Enable <b>(default)</b> 0 – Off <b>Default: 00011111</b>

## 2.6 TX RF Modules Configuration

Table 15: TX RF modules configuration memory map (user mode)

Address (7 bits)	Bits	Description
0x40	7-2 1  0	Not used EN : TXRF modules enable 0 – TXRF modules powered down 1 – TXRF modules enabled ( <b>default</b> ) DECODE: 0 – decode control signals ( <b>default</b> ) 1 – use control signals from test mode registers <b>Default:</b> 00000010
0x41	7-5 4-0	Not used VGA1GAIN[4:0]: TXVGA1 gain, log-linear control LSB=1dB, encoded as shown below: code                      Gain [dB] =====
		00000                      -35 00001                      -34 ... 10101                      -14 ( <b>default</b> ) ... 11110                      -5 11111                      -4 <b>Default:</b> 00010101
0x42	7-0	VGA1DC_I[7:0]: TXVGA1 DC shift control, LO leakage cancellation LSB=0.0625mV, encoded as shown below: code                      DC Shift [mV] =====
		00000000                      -16 ... 01111111                      -0.0625 10000000                      0 ( <b>default</b> ) 10000001                      -0.0625 ... 11111111                      15.9375 <b>Default:</b> 10000000
0x43	7-0	VGA1DC_Q[7:0]: TXVGA1 DC shift control, LO leakage cancellation LSB=0.0625mV, encoded as shown below: code                      DC Shift [mV] =====
		00000000                      -16 ... 01111111                      -0.0625 10000000                      0 ( <b>default</b> ) 10000001                      -0.0625 ... 11111111                      15.9375 <b>Default:</b> 10000000
0x44	7-5 4-2      1  0	Not used PA_EN[2:0]: VGA2 power amplifier (TX output) selection PA_EN[2:1]                      PA1                      PA2 =====
		00                      OFF                      OFF 01                      ON                      OFF ( <b>default</b> ) 10                      OFF                      ON 11                      OFF                      OFF PA_EN[0]: Reserved, set it to 0 PD_DRVAUX: AUXPA, auxiliary (RF loop back) PA power down 0 – powered up 1 – powered down ( <b>default</b> ) PD_PKDET: Power down for envelop/peak detectors 0 – powered up 1 – powered down ( <b>default</b> ) <b>Default:</b> 00001011

Table 16: TX RF modules configuration memory map (user mode) (continued)

Address (7 bits)	Bits	Description										
0x45	7-3       2-0	<p>VGA2GAIN[4:0]: TXVGA2 gain control, log-linear control LSB=1dB, encoded as shown below:</p> <table> <thead> <tr> <th>code</th> <th>Gain [dB]</th> </tr> </thead> <tbody> <tr> <td>00000</td> <td>0 <b>(default)</b></td> </tr> <tr> <td>00001</td> <td>1</td> </tr> <tr> <td>11001</td> <td>25 ...</td> </tr> <tr> <td>11111</td> <td>25</td> </tr> </tbody> </table> <p>ENVD[2:0]: Controls envelop/peak detector analogue MUX ENVD[1:0]: Detector select, MUX provides 00 – AUXPA envelop detector output <b>(default)</b> 01 – AUXPA peak detector output 10 – PA1 envelop detector output 11 – PA2 envelop detector output ENVD[2]: Selects the signal for AC coupling, MUX provides 0 – reference DC generated inside the selected detector <b>(default)</b> 1 – average of the selected detector output <b>Default: 00000000</b></p>	code	Gain [dB]	00000	0 <b>(default)</b>	00001	1	11001	25 ...	11111	25
code	Gain [dB]											
00000	0 <b>(default)</b>											
00001	1											
11001	25 ...											
11111	25											
0x46	7-4   3-2  1  0	<p>PKDBW[3:0]: Controls the bandwidth of the envelop and peak detectors 0000 – Minimum bandwidth, envelop ~1MHz, peak 30kHz <b>(default)</b> 1111 – Maximum bandwidth, envelop ~15MHz, peak ~300KHz</p> <p>LOOPBEN[1:0]: Base band loop back switches control 00 – Switch open <b>(default)</b> 11 – Switch closed.</p> <p>FST_PKDET: Shorts the resistor in the envelop/peak detector to speed up charging for faster response. After the initial charge up, it should be disabled to achieve a LPF function. 0 – switch open, LPF function in effect <b>(default)</b> 1 – resistor shorted (no LPF function)</p> <p>FST_TXHFBIAS: Bias stage of high frequency TX part has large resistors to filter the noise. However, they create large settling time. This switch can be used to short those resistors during the initialization and then it may be needed to open it to filter the noise, in case the noise is too high. 0 – switch open (noise filtering functional) <b>(default)</b> 1 – resistors shorted (short settling - no noise filtering) <b>Default: 00000000</b></p>										
0x47	7-4   3-0	<p>ICT_TXLOBUF[3:0]: Controls the bias current of the LO buffer. Higher current will increase the linearity. LSB=5/6mA. 0000 – minimum current 0110 – TXMIX takes 5mA for buffer <b>(default)</b> 1111 – maximum current</p> <p>VBCAS_TXDRV[3:0]: The linearity of PAs depends on the bias at the base of the cascode npn's in the PA cells. Increasing the VBCAS will lower the base of the cascode npn. 0000 – maximum base voltage <b>(default)</b> 1111 – minimum base voltage <b>Default: 01100000</b></p>										
0x48	7-5 4-0	<p>Not used</p> <p>ICT_TXMIX[4:0]: Controls the bias current of the mixer. Higher current will increase the linearity. LSB=1mA. 00000 – 0 mA 01100 – TXMIX takes 12mA for each cell <b>(default)</b> 11111 – 31 mA <b>Default: 00001100</b></p>										
0x49	7-5 4-0	<p>Not used</p> <p>ICT_TXDRV[4:0]: Controls the bias current of the PAs. Higher current will increase the linearity. LSB=1mA. 00000 – 0 mA 01100 – PAs take 12mA for each cell <b>(default)</b> 11111 – 31 mA <b>Default: 00001100</b></p>										

Table 17: TX RF modules configuration memory map (test mode)

Address (7 bits)	Bits	Description																		
0x4A	7-5 4 3 2 1 0	<p>Not used</p> <p>PW_VGA1_I: VGA1, I channel power control 0 – powered down 1 – powered up <b>(default)</b></p> <p>PW_VGA1_Q: VGA1, Q channel power control 0 – powered down 1 – powered up <b>(default)</b></p> <p>PD_TXDRV: Power down for PAs and AUXPA. 0 – PA1, PA2 and AUXPA can be separately controlled <b>(default)</b> 1 – PA1, PA2 and AUXPA all disabled</p> <p>PD_TXLOBUF: Power down for TXLOBUF 0 – powered up <b>(default)</b> 1 – powered down</p> <p>PD_TXMIX: Power down for TXMIX 0 – powered up <b>(default)</b> 1 – powered down</p> <p><b>Default: 00011000</b></p>																		
0x4B	7–0	<p>VGA1GAIN[7:0]: TXVGA1 gain control, raw access LSB=1dB, encoded as shown below:</p> <table style="margin-left: 40px;"> <thead> <tr> <th style="text-align: left;">code</th> <th style="text-align: left;">Gain [dB]</th> </tr> </thead> <tbody> <tr> <td colspan="2">=====</td> </tr> <tr> <td>00000110</td> <td>-35</td> </tr> <tr> <td>00000111</td> <td>-34</td> </tr> <tr> <td>...</td> <td></td> </tr> <tr> <td>01010000</td> <td>-14 <b>(default)</b></td> </tr> <tr> <td>...</td> <td></td> </tr> <tr> <td>11100011</td> <td>-5</td> </tr> <tr> <td>11111111</td> <td>-4</td> </tr> </tbody> </table> <p><b>Default: 01010000</b></p>	code	Gain [dB]	=====		00000110	-35	00000111	-34	...		01010000	-14 <b>(default)</b>	...		11100011	-5	11111111	-4
code	Gain [dB]																			
=====																				
00000110	-35																			
00000111	-34																			
...																				
01010000	-14 <b>(default)</b>																			
...																				
11100011	-5																			
11111111	-4																			
0x4C	7–0	<p>G_TXVGA2[8:1]: Controls the gain of PA1, PA2 and AUXPA, raw access For PA1, PA2: Gain=20*log10(0.038*G_TXVGA2[8:0]) For AUXPA: Only 4 LSB's are used, max gain ~22dB <b>Default: 00000000, 0dB gain</b></p>																		
0x4D	7 6-0	<p>G_TXVGA2[0]: Controls the gain of PA1, PA2 and AUXPA, LSB Not used <b>Default: 00000000</b></p>																		
0x4E	7-0	<p>SPARE0[7:0]: Spare configuration register. <b>Default: 00000000</b></p>																		
0x4F	7–0	<p>SPARE1[7:0]: Spare configuration register. <b>Default: 00000000</b></p>																		

## 2.7 RX VGA2 Configuration

Table 18: RX VGA2 configuration memory map (user mode)

Address (7 bits)	Bits	Description
0x60	7-6 5-0	Not used DC_REGVAL[5:0]: Value from DC Calibration module selected by DC_ADDR. <b>Read Only.</b>
0x61	7-5 4-2 1 0	Not used DC_LOCK[2:0]: Lock pattern register. Locked, when register value is not "000" nor "111". DC_CLBR_DONE : indicates calibration status. 1 – calibration in progress; 0 – calibration is done. DC_UD: Value from DC module comparator, selected by DC_ADDR 1 – Count Up; 0 – Count Down. <b>Read Only.</b>
0x62	7-6 5-0	Not used DC_CNTVAL[5:0] : Value to load into selected (by DC_ADDR) DC calibration module. <b>Default: 00011111</b>
0x63	7-6 5 4 3 2-0	Not used DC_START_CLBR: Start calibration command on module, selected by DC_ADDR 1 – Start Calibration; 0 – Deactivate Start Calibration command. <b>(default)</b> DC_LOAD: Load value from DC_CNTVAL to module, selected by DC_ADDR 1 – Load Value; 0 – Deactivate Load Value command. <b>(default)</b> DC_SRESET: resets all DC Calibration modules 1 – Reset inactive; <b>(default)</b> 0 – Reset active. DC_ADDR[3:0]: Active calibration module address. 000 – DC reference module. 001 – First gain stage (VGA2A), I channel. 010 – First gain stage (VGA2A), Q channel. 011 – Second gain stage (VGA2B), I channel. 100 – Second gain stage (VGA2B), Q channel. 101 – 111 Not used. <b>Default: 00001000</b>
0x64	7-6 5-2 1 0	Not used VCM[3:0]: RXVGA2 output common mode voltage control. VCM[3] – sign, VCM[2:0] – magnitude, LSB=50mV. 0000 – maximum positive 0111 – 900mV <b>(default)</b> 1000 – maximum negative EN : RXVGA2 modules enable 0 – RXVGA2 modules powered down 1 – RXVGA2 modules enabled <b>(default)</b> DECODE: 0 – decode control signals <b>(default)</b> 1 – use control signals from test mode registers <b>Default: 00011110</b>
0x65	7-5 4-0	Not used VGA2GAIN[4:0]: RXVGA2 gain control LSB=3dB, encoded as shown below: code                      Gain [dB] =====
		00000                      0 00001                      3 <b>(default)</b> ... 01001                      27 01010                      30 ... 10100                      60 Not recommended to be used above 30dB <b>Default: 00000001</b>

Table 19: RX VGA2 configuration memory map (test mode)

Address (7 bits)	Bits	Description
0x66	7-6 5 4 3 2 1 0	<p>PD[9:0]: Power down different modules:                      Not used                      PD[9] - DC current regulator                      1 – powered down                      0 – powered up (<b>default</b>)                      PD[8] - DC calibration DAC for VGA2B                      1 – powered down                      0 – powered up (<b>default</b>)                      PD[7] - DC calibration comparator for VGA2B                      1 – powered down                      0 – powered up (<b>default</b>)                      PD[6] - DC calibration DAC for VGA2A                      1 – powered down                      0 – powered up (<b>default</b>)                      PD[5] - DC calibration comparator for VGA2A                      1 – powered down                      0 – powered up (<b>default</b>)                      PD[4] - Band gap                      1 – powered down                      0 – powered up (<b>default</b>)</p>
0x67	7-4 3 2 1 0	<p>Not used                      PD[3] – Output buffer in both RXVGAs                      1 – powered down                      0 – powered up (<b>default</b>)                      PD[2] - RXVGA2B                      1 – powered down                      0 – powered up (<b>default</b>)                      PD[1] - RXVGA2A                      1 – powered down                      0 – powered up (<b>default</b>)                      PD[0] - Current reference                      1 – powered down                      0 – powered up (<b>default</b>)  <b>Default: 00000000 00000000</b></p>
0x68	7-4 3-0	<p>VGA2GAINB: Controls the gain of second VGA2 stage (VGA2B)                      LSB=3dB, encoded as shown below:                      Code                      Gain [dB]                      =====                      0000                      0 (<b>default</b>)                      0001                      3                      ...                      1001                      27                      1010                      30</p> <p>VGA2GAINA: Controls the gain of first VGA2 stage (VGA2A)                      LSB=3dB, encoded as shown below:                      Code                      Gain [dB]                      =====                      0000                      0                      0001                      3 (<b>default</b>)                      ...                      1001                      27                      1010                      30  <b>Default: 00000001</b></p>
0x6E	7-0	<p>SPARE0[7:0]: Spare configuration register.  <b>Default: 00000000</b></p>
0x6F	7-0	<p>SPARE1[7:0]: Spare configuration register.  <b>Default: 00000000</b></p>



## 2.8 RX FE Modules Configuration

Table 20: RX FE modules configuration memory map (user mode)

Address (7 bits)	Bits	Description
0x70	7-2 1  0	Not used DECODE: 0 – decode control signals ( <b>default</b> ) 1 – use control signals from test mode registers EN: RXFE modules enable EN =0 – Top modules powered down EN =1 – Top modules enabled ( <b>default</b> ) <b>Default:</b> 00000001
0x71	7  6-0	IN1SEL_MIX_RXFE: Selects the input to the mixer 1 – input 1 is selected, shorted on-chip to LNA internal output ( <b>default</b> ) 0 – input 2 is selected, connected to pads. DCOFF_I_RXFE[6:0]: DC offset cancellation, I channel. Code is Sign(<6>)-Magnitude(<5:0>), signed magnitude format. 0000000 – ( <b>default</b> ) <b>Default:</b> 10000000
0x72	7  6-0	INLOAD_LNA_RXFE: To select the internal load for the LNA . 1 – internal load is active ( <b>default</b> ) 0 – internal node is disabled. DCOFF_Q_RXFE[6:0]: DC offset cancellation, Q channel. Code is Sign(<6>)-Magnitude(<5:0>), signed magnitude format. 0000000 – ( <b>default</b> ) <b>Default:</b> 10000000
0x73	7  6-0	XLOAD_LNA_RXFE: To select the external load for the LNA . 1 – external load is active 0 – external node is disabled ( <b>default</b> ) IP2TRIM_I_RXFE[6:0]: IP2 cancellation, I channel. Code is Sign(<6>)-Magnitude(<5:0>), signed magnitude format. 0000000 – ( <b>default</b> ) <b>Default:</b> 00000000
0x74	7 6-0	Not used IP2TRIM_Q_RXFE[6:0]: IP2 cancellation, Q channel. Code is Sign(<6>)-Magnitude(<5:0>), signed magnitude format. 0000000 – ( <b>default</b> ) <b>Default:</b> 00000000
0x75	7-6  5-4  3-0	G_LNA_RXFE[1:0]: LNA gain mode control. 11 – max gain ( <b>default</b> ) 10 – mid gain (max gain-6dB) 01 – LNA bypassed. 00 – LNASEL_RXFE[1:0]: Selects the active LNA. 00 – all LNA's disabled 01 – LNA1 active ( <b>default</b> ) 10 – LNA2 active 11 – LNA3 (GSM) active CBE_LNA_RXFE[3:0]: Controls the capacitance parallel to the BE of the input NPN transistors. To be used at lower frequencies for easier matching. For LNA1 and LNA2 only. 0000 – ( <b>default</b> ) <b>Default:</b> 11010000
0x76	7 6-0	Not used RFB_TIA_RXFE[6:0]: Feedback resistor control of the TIA (RXVGA1) to set the mixer gain. If =120 --> mixer gain = 30dB ( <b>default</b> ) If =102 --> mixer gain = 19dB If = 2 --> mixer gain = 5dB <b>Default:</b> 01111000

Table 21: RX FE modules configuration memory map (user mode) (continued)

Address (7 bits)	Bits	Description
0x77	7 6-0	Not used CFB_TIA_RXFE[6:0]: Feedback capacitor for the TIA (RXVGA1) to limit the BW. If =0, min cap --> BW~45MHz for gain of 30dB. <b>(default)</b> If = 19 --> BW=2.5MHz for MixGain=30dB and at TT. This cap is supposed to be set according to the RC time constant to have almost constant BW over the corners for optimum CDMA performance. Software will control it using the information from the LPF calibration circuit.  To set the code vs. corners, use the following equation: Code(process) = int[ Code(Nominal)*(RCCAL_LPF-3)*1.04 ] <b>Default:</b> 00000000
0x78	7-6 5-0	Not used RDLEXT_LNA_RXFE[5:0]: Controls the on-chip LNA load resistor for the external load mode of the LNA. In practice, this will be set to high value, the output will be ac coupled, and the actual load is defined on PCB. 011100- <b>(default)</b> <b>Default:</b> 00011100
0x79	7-6 5-0	Not used RDLINT_LNA_RXFE[5:0]: Controls the on-chip LNA load resistor for the internal load mode of the LNA. 011100- <b>(default)</b> <b>Default:</b> 00011100
0x7A	7-4 3-0	ICT_MIX_RXFE[3:0]: Control for tweaking the bias current for mixer. 0000 - 0 bias current 0111 - nominal bias current <b>(default)</b> 1111 - 2.1 x nominal bias current ICT_LNA_RXFE[3:0]: Control for tweaking the bias current for LNA. 0000 - 0 bias current 0111 - nominal bias current <b>(default)</b> 1111 - 2.1 x nominal bias current <b>Default:</b> 01110111
0x7B	7-4 3-0	ICT_TIA_RXFE[3:0]: Control for tweaking the bias current for TIA (RXVGA1). 0000 - 0 bias current 0111 - nominal bias current <b>(default)</b> 1111 - 2.1 x nominal bias current ICT_MXLOB_RXFE[3:0]: Control for tweaking the bias current for mixer LO buffer. 0000 - 0 bias current 0111 - nominal bias current <b>(default)</b> 1111 - 2.1 x nominal bias current <b>Default:</b> 01110111
0x7C	7 6-3 2 1-0	Not used LOBN_MIX_RXFE[3:0]: Tweak for the LO bias of the mixer for optimum linearity. 0000 - minimum bias voltage 0011 - <b>(default)</b> 1111 - maximum bias voltage RINEN_MIX_RXFE: Termination resistor on external mixer input enable 1 - Active 0 - Inactive <b>(default)</b> G_FINE_LNA3_RXFE[1:0]: LNA3 fine gain adjustment 00 - +0 dB <b>(default)</b> 01 - +1 dB 10 - +2 dB 11 - +3 dB <b>Default:</b> 00011000

Table 22: RX FE modules configuration memory map (test mode)

Address (7 bits)	Bits	Description
0x7D	7-4 3-0	Not used Reserved <b>Default:</b> 00000000
0x7E	7-0	SPARE0[7:0] <b>Default:</b> 00000000
0x7F	7-0	SPARE1[7:0] <b>Default:</b> 00000000

Open Source Community



# 3

## Control Block Diagrams

### 3.1 SPI READ/WRITE Pseudo Code

```
//-----  
// Write command, SPI module address, register address  
// Read data  
//-----  
void SPI_Read(BYTE COMMAND)  
{  
    BYTE DATA;    //We will read data there  
  
    //Write Command and Address (MSB First)  
    //First 1 bit (MSB) = Command  
    //Next 3 bits = SPI memory block address  
    //Next 4 (LSBs) bits = Register Address  
    for(int i=7; i>=0; i--)  
    {  
        if(i'th bit in COMMAND is '1')  
        {  
            Set Data Output line to '1';  
        }  
        else  
        {  
            Set Data Output line to '0';  
        }  
        Apply Rising and Falling CLK signal edges to CLK line;  
    };  
  
    //Read Data (MSB First)  
    //Note: At this point we have data MSB valid from the chip.  
    for(int i=7; i>=0; i--)  
    {  
        if(there is '1' at the Data Input Line)  
        {  
            Set i'th bit in DATA '1';  
        }  
        else  
        {  
            Set i'th bit in DATA '0';  
        }  
        Apply Rising and Falling CLK signal edges to CLK line;  
    };  
};
```

```

//-----
// Write data to the chip:
// First byte: Command, SPI module address, register address
// Second byte: Data
//-----
void SPI_Write(BYTE COMMAND, BYTE DATA)
{
    //Write Command, Address
    for(int i=7; i>=0; i--)
    {
        if(i'th bit in COMMAND is '1')
        {
            Set Data Output line to '1';
        }
        else
        {
            Set Data Output line to '0';
        }
    };
    Apply Rising and Falling CLK signal edges to CLK line;
};

//Write Data
for(int i=7; i>=0; i--)
{
    if(i'th bit in DATA is '1')
    {
        Set Data Output line to '1';
    }
    else
    {
        Set Data Output line to '0';
    }
};
    Apply Rising and Falling CLK signal edges to CLK line;
};
};

```

### 3.2 Loopback and Bypass Modes

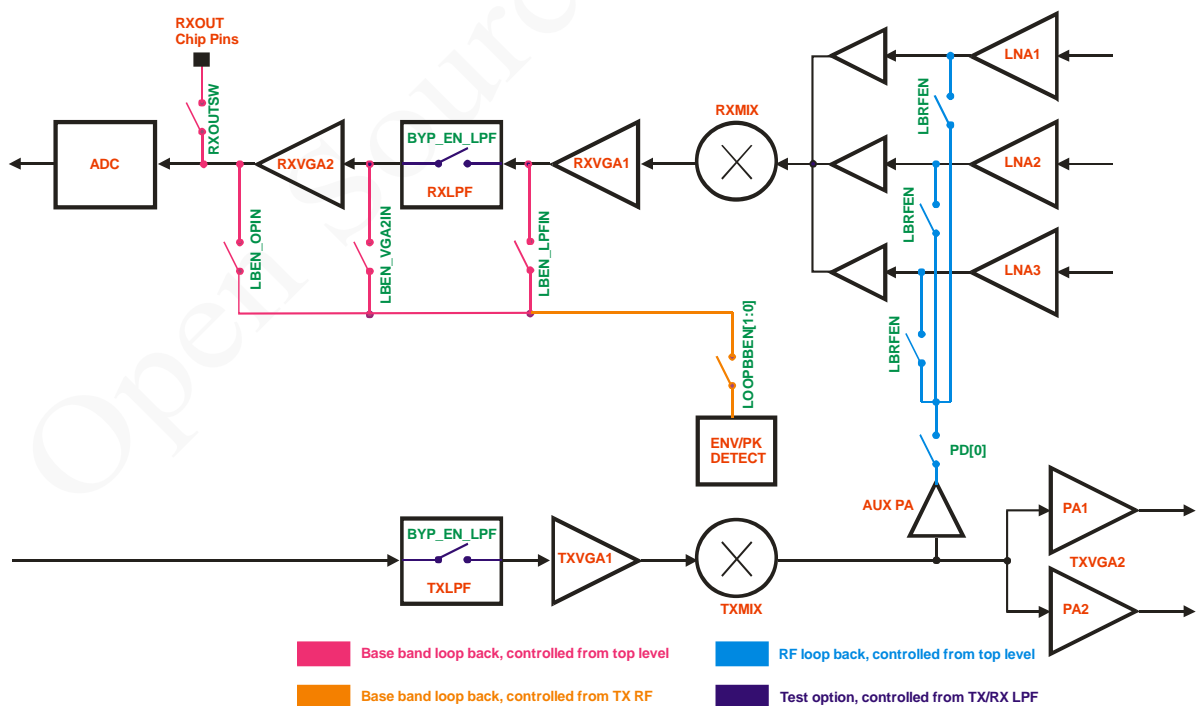

Figure 3.1: Loop back and test options

### 3.3 Envelop and Pick Detector Multiplexer

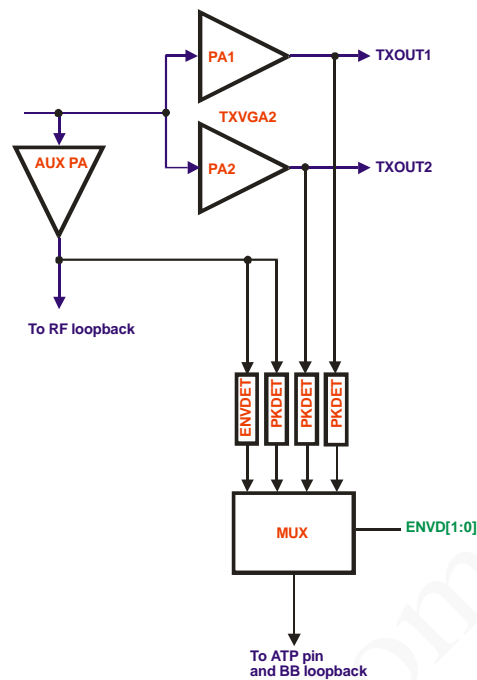

Figure 3.2: Envelop/pick detector analogue MUX

### 3.4 TX/RX PLL

The frequency setting for both TX and RX PLLs is the same as described here. TX PLL SPI registers are at x001xxxx and TX PLL registers are at x010xxxx.

To configure the PLL there are a number of variables which need to be set.

- Integer and fractional part of the divider
- FRANGE value
- VCO CAP, charge pump current ( $I_{cp}$ ) and charge pump offset current ( $I_{off}$ )

This assumes the given loop filter value with a loop BW of 50kHz is used.

### 3.4.1 FREQSEL

From the table below select the correct value for FREQSEL[5:0]

FREQSEL[5:0]:		
Frequency Range (GHz)		Value
0.2325	0.285625	100111
0.285625	0.336875	101111
0.336875	0.405	110111
0.405	0.465	111111
0.465	0.57125	100110
0.57125	0.67375	101110
0.67375	0.81	110110
0.81	0.93	111110
0.93	1.1425	100101
1.1425	1.3475	101101
1.3475	1.62	110101
1.62	1.86	111101
1.86	2.285	100100
2.285	2.695	101100
2.695	3.24	110100
3.24	3.72	111100

For example, UMTS Band I centre frequency 2140MHz is in range 1.86 to 2.285GHz hence FREQSEL = 100100 (0x24).

### 3.4.2 Integer and Fractional Part of the Divider

For wanted LO frequency  $f_{LO}$  and given PLL reference clock frequency  $f_{REF}$ , calculate integer and fractional part of the divider as below.

First, find temporary variable  $x$  from the 3 least significant bits of the FREQSEL value:

$$x = 2^{FREQSEL[2:0]-3}$$

Use  $x$  to calculate NINT and NFRAC:

$$NINT = \left\lfloor \frac{x * f_{LO}}{f_{REF}} \right\rfloor,$$

$$NFRAC = \left\lfloor 2^{23} \left[ \frac{x * f_{LO}}{f_{REF}} - NINT \right] \right\rfloor,$$

and store the values in NINT/NFRAC registers at address 0x10-0x13 for TXPLL and 0x20-0x23 for RX PLL.

For example  $f_{LO}$  is band 1 centre frequency of 2140MHz, and  $f_{REF} = 30.72$ MHz:



$$FREQSEL[5:0] = 100100, FREQSEL[2:0] = 100 = 0x4 = 4$$

$$x = 2^{FREQSEL[2:0]-3} = 2^{4-3} = 2^1 = 2$$

$$NINT = \left\lfloor \frac{x * f_{LO}}{f_{REF}} \right\rfloor = \left\lfloor \frac{2 * 2140}{30.72} \right\rfloor = 139$$

$$NFRAC = \left\lfloor 2^{23} \left[ \frac{x * f_{LO}}{f_{REF}} - NINT \right] \right\rfloor = \left\lfloor 2^{23} \left[ \frac{2 * 2140}{30.72} - 139 \right] \right\rfloor = 2708821$$

### 3.4.3 VCO Capacitor, Icp and Ioff Selection

For the PLL loop filter implemented on both evaluation and reference LMS6002D boards, loop bandwidth of 50kHz and optimum PLL phase noise performance, the following charge pump current setup is recommended:

- Charge pump current Icp=1200uA (default)
- Charge pump current offset up Ioff up = 30uA.
- Charge pump current offset down Ioff down = 0uA (default).

Regarding VCOCAP selection, an flexible algorithm, based on monitoring on chip Vtune comparators state, is developed as described below.

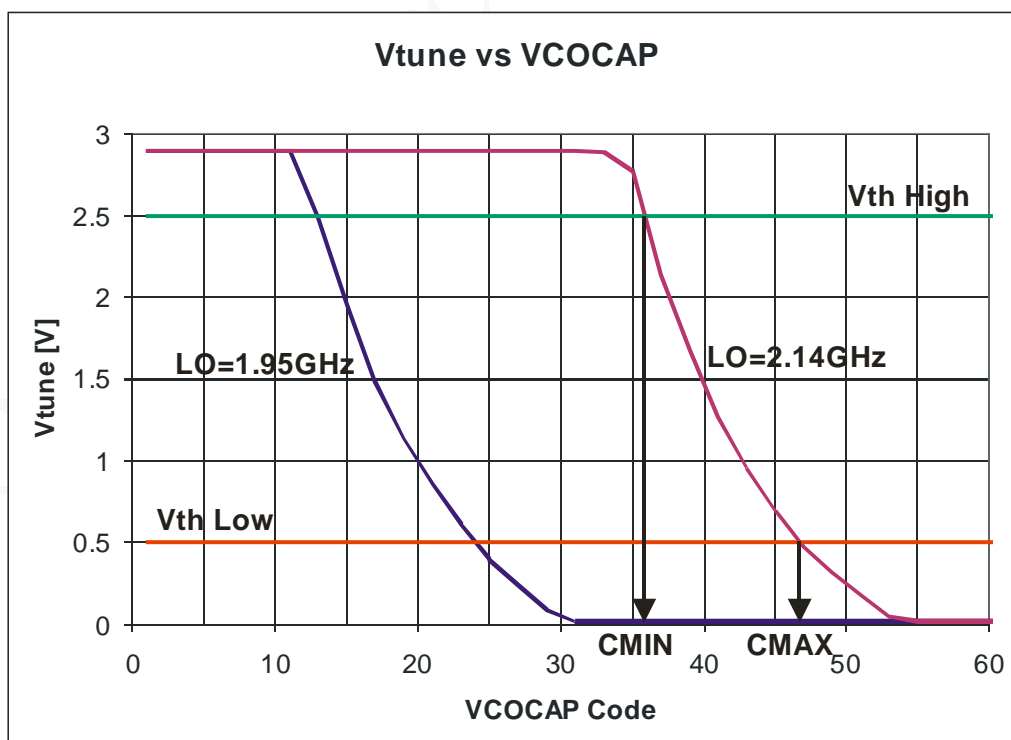

Figure 3.3: VCO capacitance selection

Figure 3.3 shows typical measured Vtune variation with the VCOCAP codes for the two target LO frequencies, 1.95GHz and 2.14GHz. Obviously, Vtune is changing from 2.9V down to 0V. However, PLL lock is guaranteed only when Vtune is in the range 0.5V-2.5V. Also, for the best phase noise performance, Vtune should be kept around the middle of the range i.e. 1.5V.

There are two on chip Vtune comparators per PLL as shown in Figure 3.4. Their threshold voltages are set to Vth Low=0.5V and Vth High=2.5V. The state of the comparators can be obtained by powering them up (register 0x1B for TXPLL or 0x2B for RXPLL, bit 3) and reading the register 0x1A for TXPLL or 0x2A for RXPLL, bits 7-6. True table is given below.

VTUNE_H	VTUNE_L	Status
0	0	OK, Vtune in range
1	0	Vtune is high (> 2.5V), PLL lock not guaranteed.
0	1	Vtune is Low (< 0.5V), PLL lock not guaranteed.
1	1	Not possible, check SPI connections.

These can be used to choose VCOCAP code. All we need to find is the code CMIN when comparators change the state from "10" to "00" and the code CMAX when the comparators change the state from "00" to "01". Optimum VCOCAP code is then the middle one between CMIN and CMAX. For LO=2.4GHz, this is illustrated in Figure 3.3. In this case, optimum code is around 41.

The algorithm is summarised as below.

1. Select correct FREQSEL as explained in section 3.4.1.
2. Set target LO frequency (NINT, NFRAC) as explained in section 3.4.2.
3. Sweep VCOCAP codes from 0-63. Monitor the state of Vtune comparators.
  - 3.a. Record the code CMIN when Vtune comparators state changes from "10" to "00" (PLL enters 'in range' state).
  - 3.b. Record the code CMAX when Vtune comparators state changes from "00" to "01" (PLL leaves 'in range' state).
  - 3.c. Select the middle code between CMIN and CMAX (  $C=(CMIN+CMAX)/2$  ).

Note that faster search algorithm (replacement for step 3 above) can be implemented as shown in Section 4.6.

Once the PLL is set, Vtune comparators can also be used as lock (in range) indication.

### 3.4.4 PLL Control

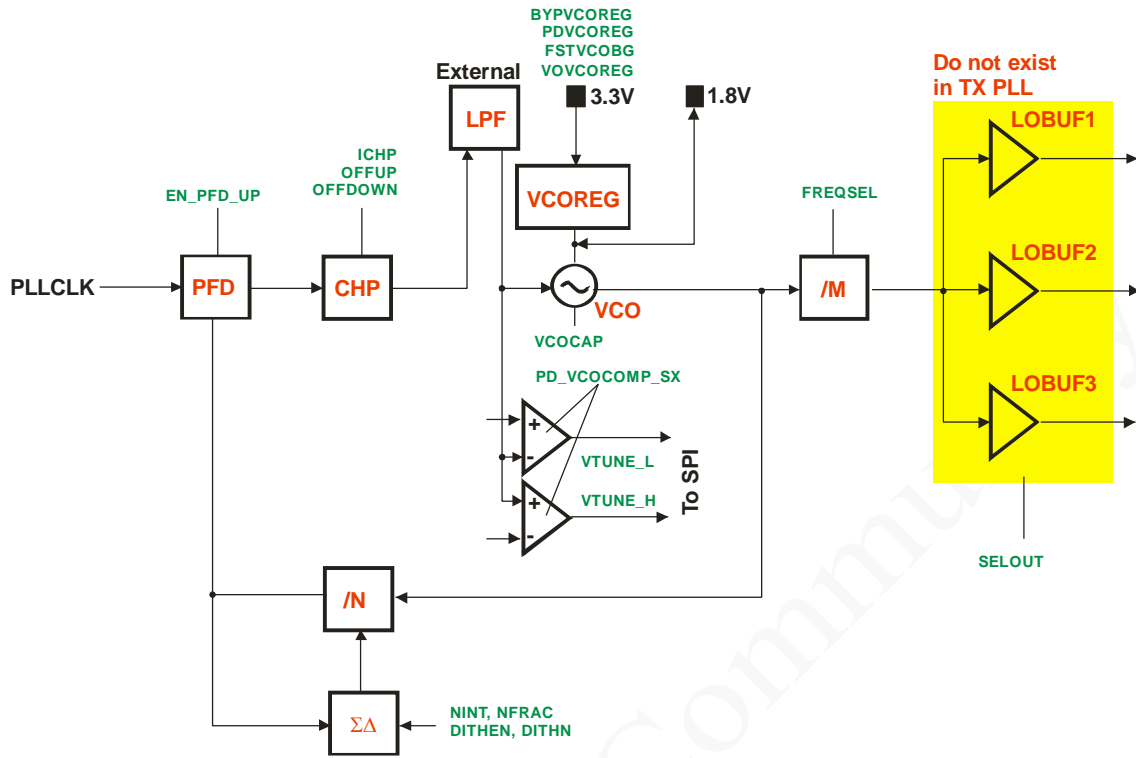

Figure 3.4: PLL control

### 3.5 TX/RX LPF

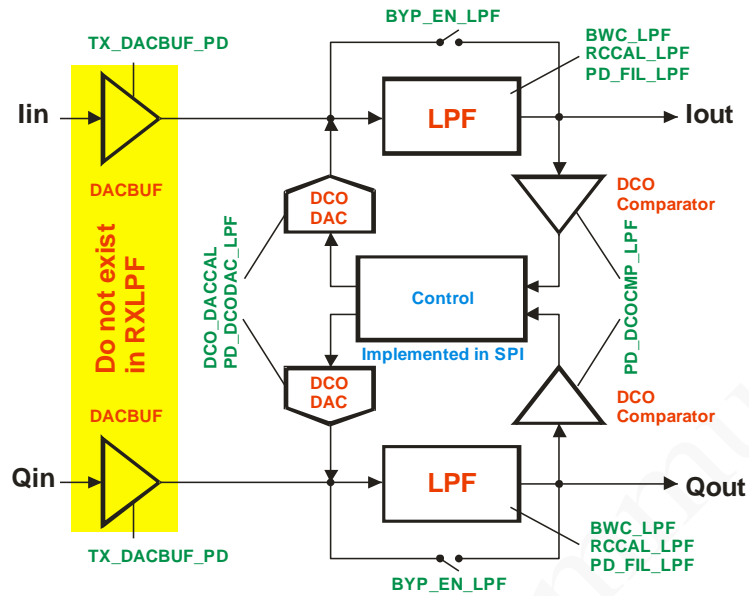

Figure 3.5: TX/RX LPF control

### 3.6 TX RF

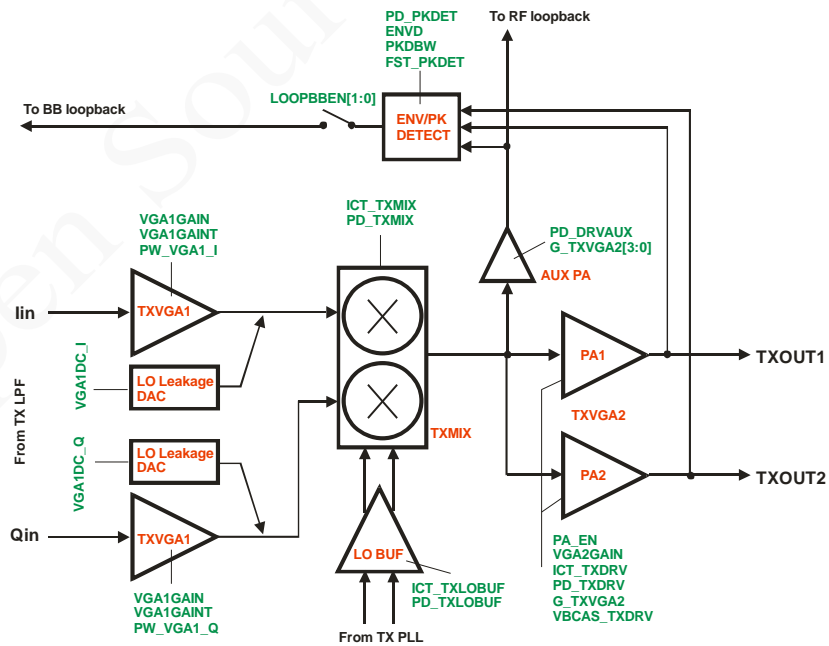

Figure 3.6: TX RF control

### 3.7 RXVGA2

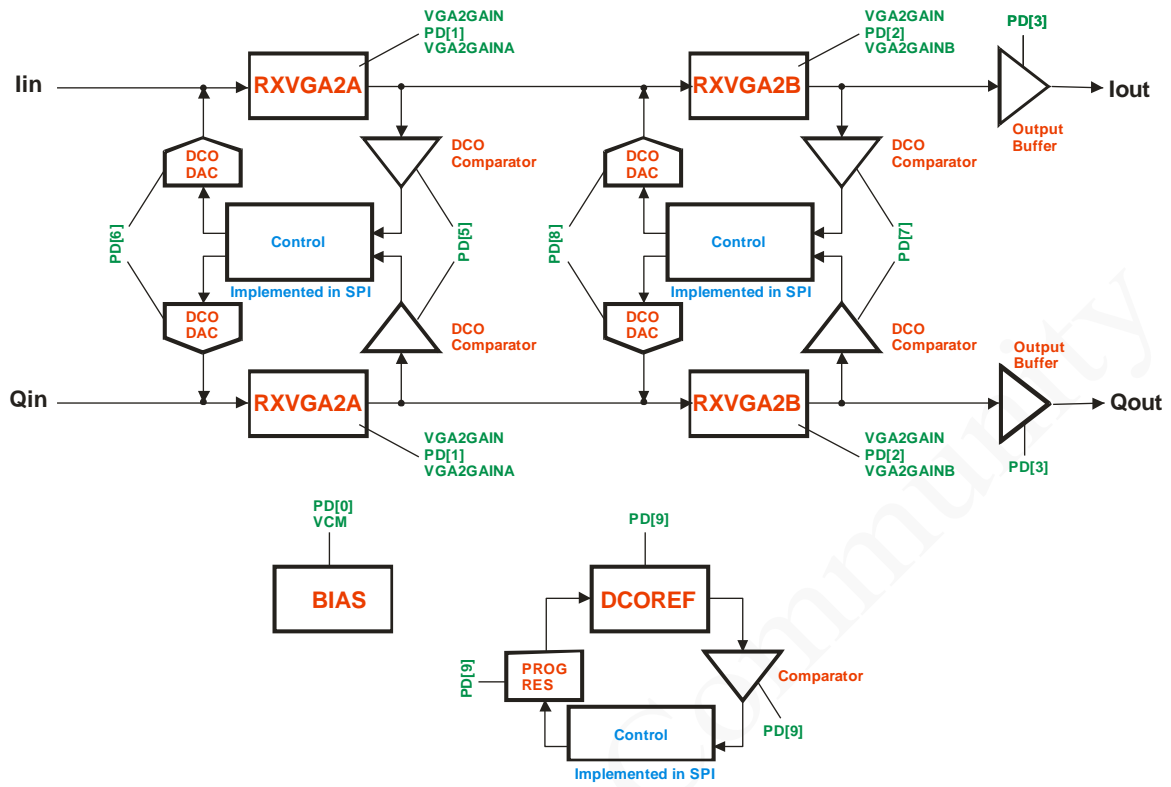

Figure 3.7: RXVGA2 control

### 3.8 RX FE

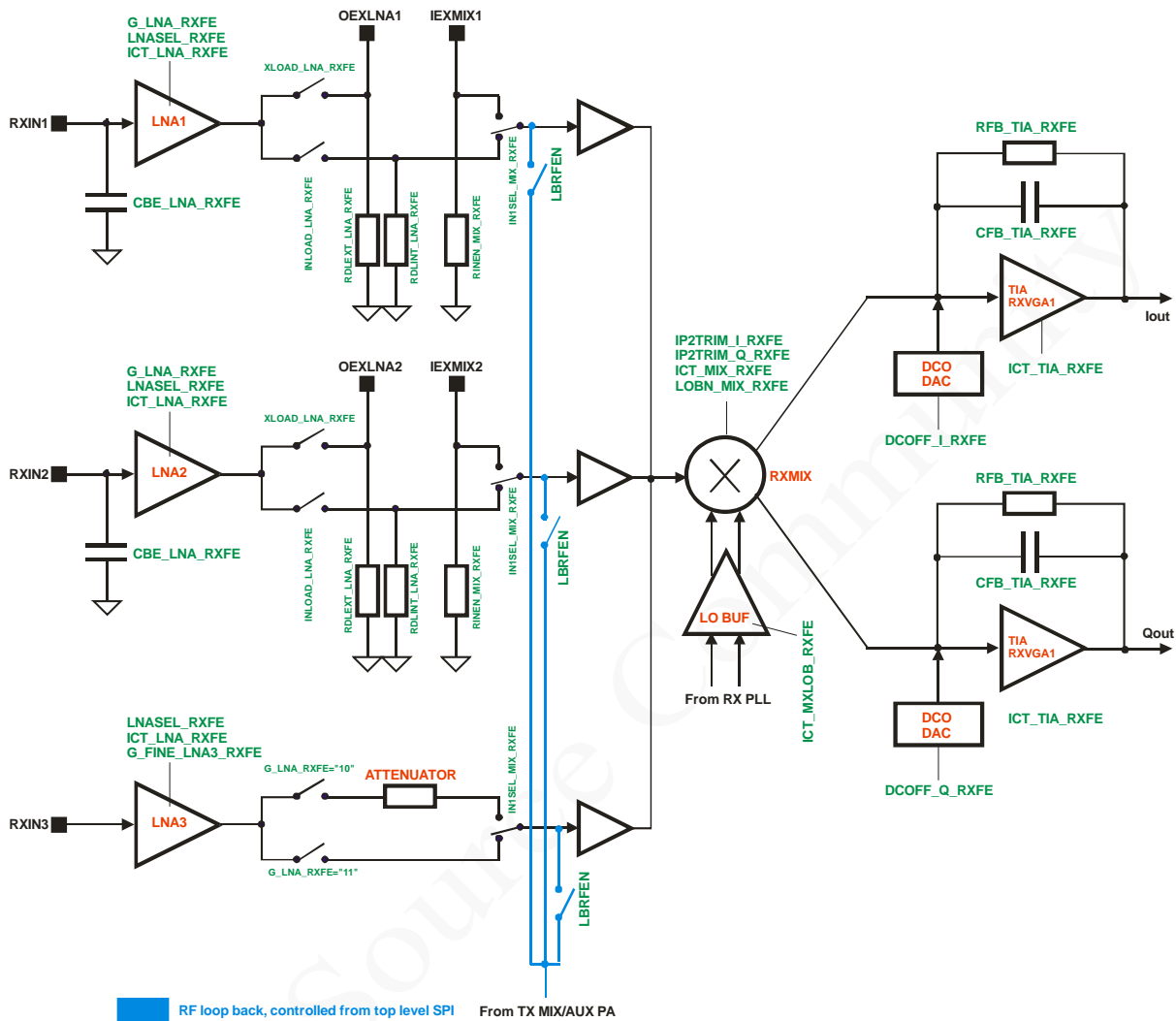

Figure 3.8: RX FE control

# 4

## Calibration Flow Charts

Open Source Community

## 4.1 General DC Calibration Procedure

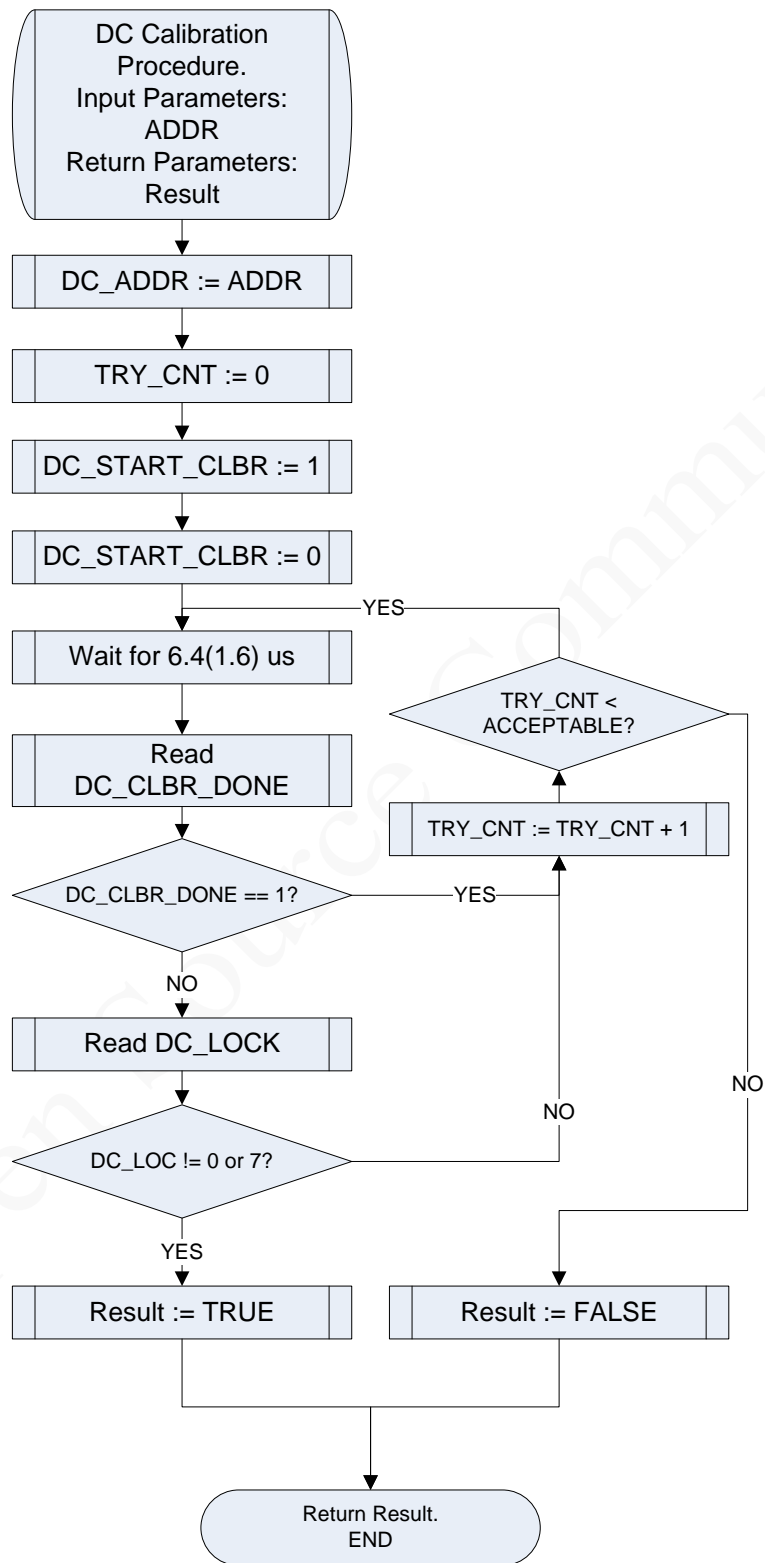

Figure 4.1



## 4.2 DC Offset Calibration of LPF Tuning Module

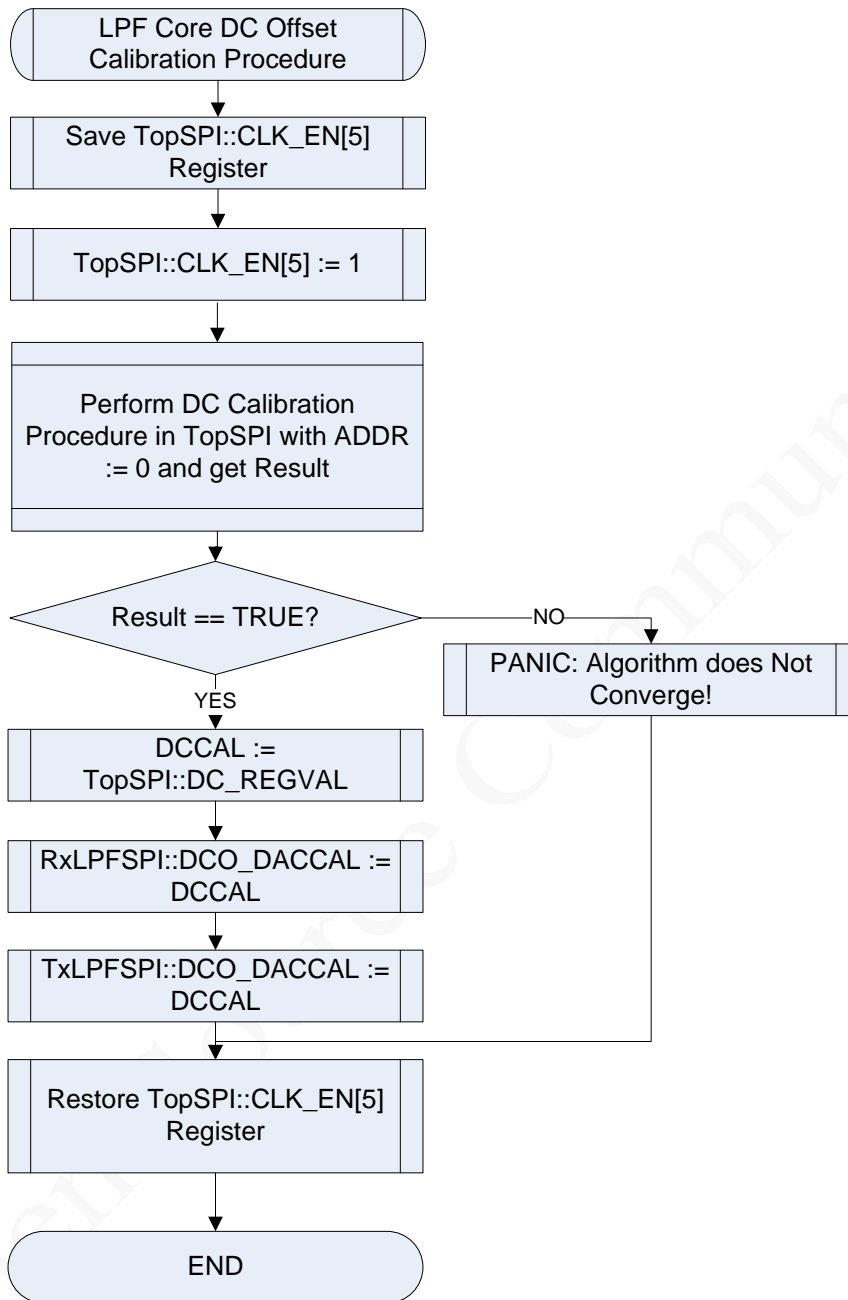

Figure 4.2

### 4.3 TX/RX LPF DC Offset Calibration

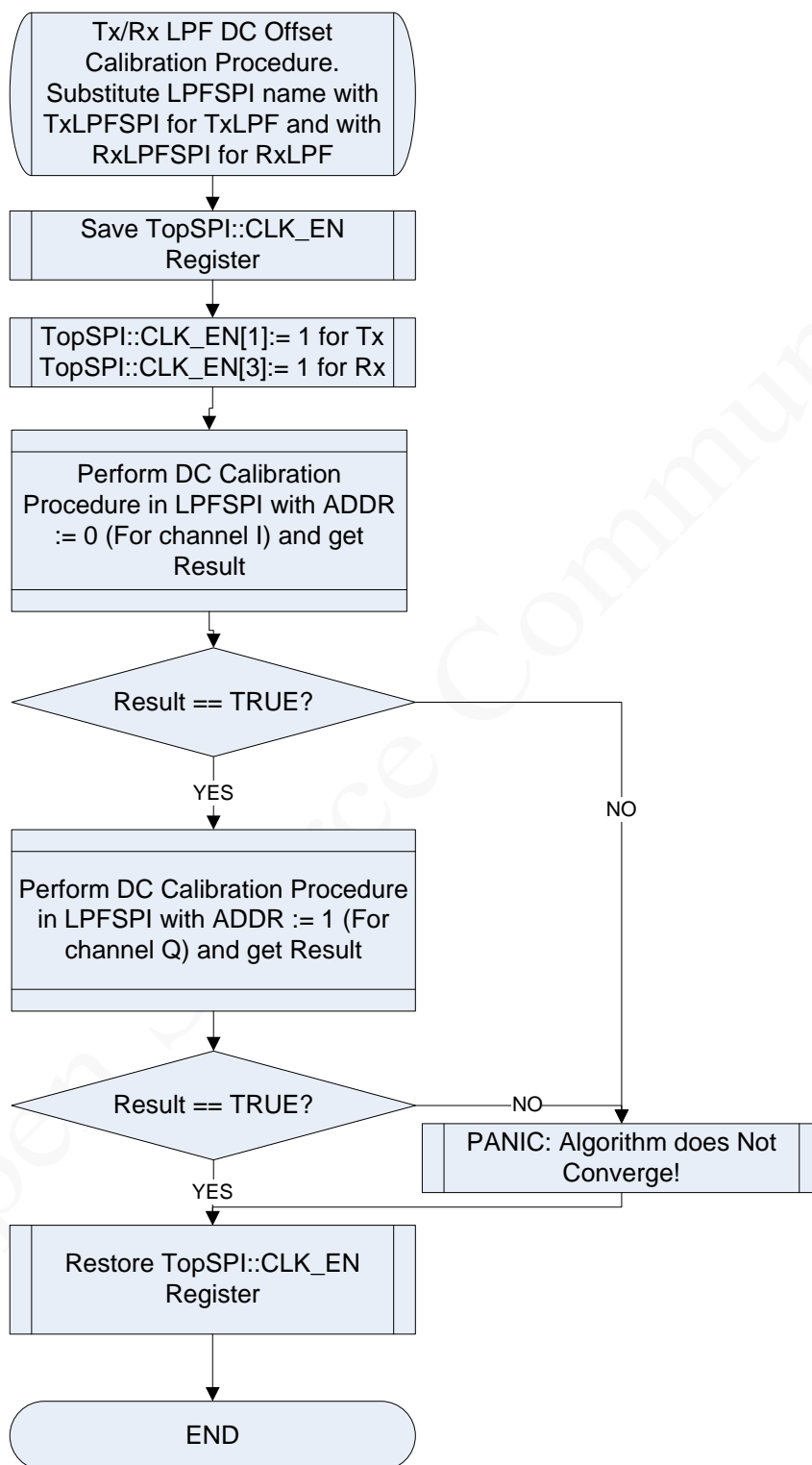

Figure 4.3

### 4.4 RXVGA2 DC Offset Calibration

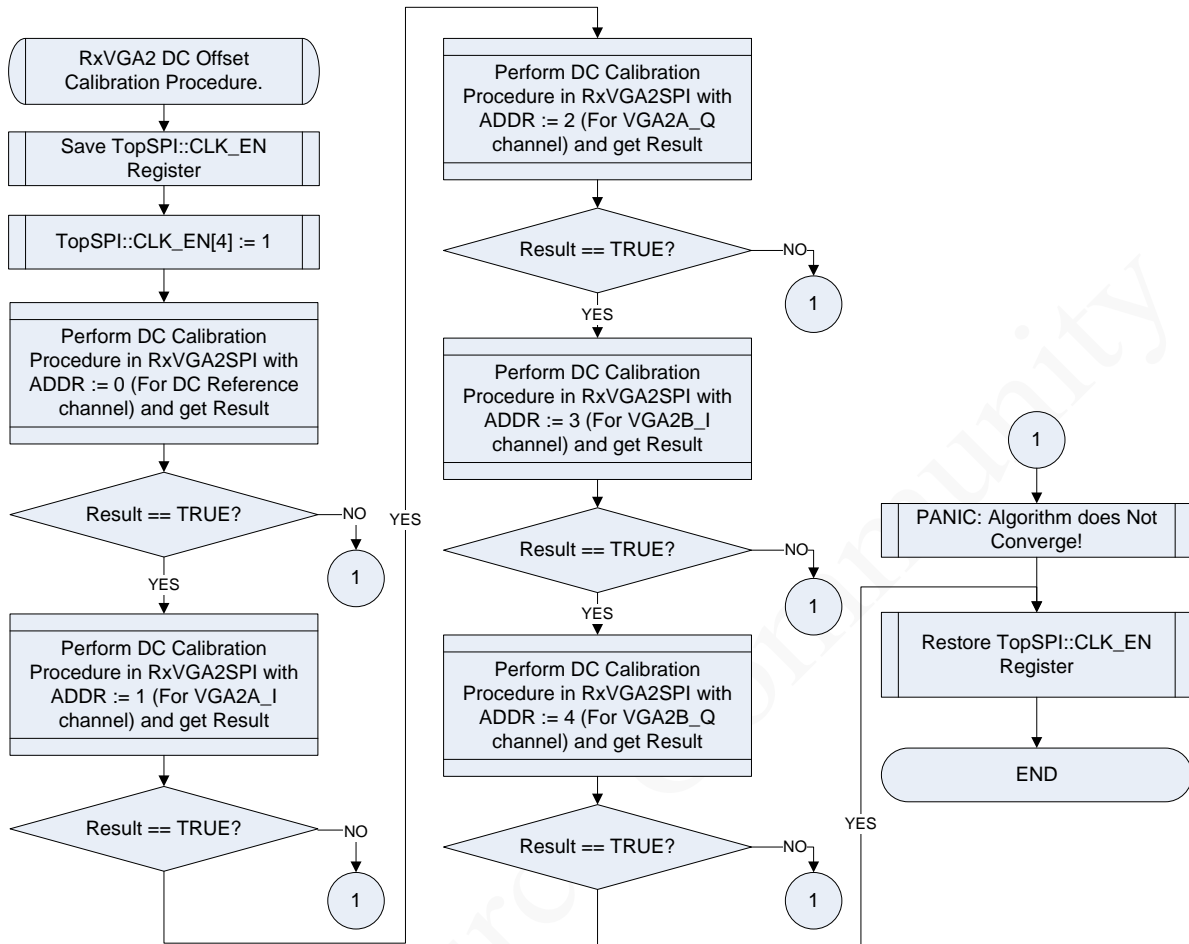

Figure 4.4

## 4.5 LPF Bandwidth Tuning

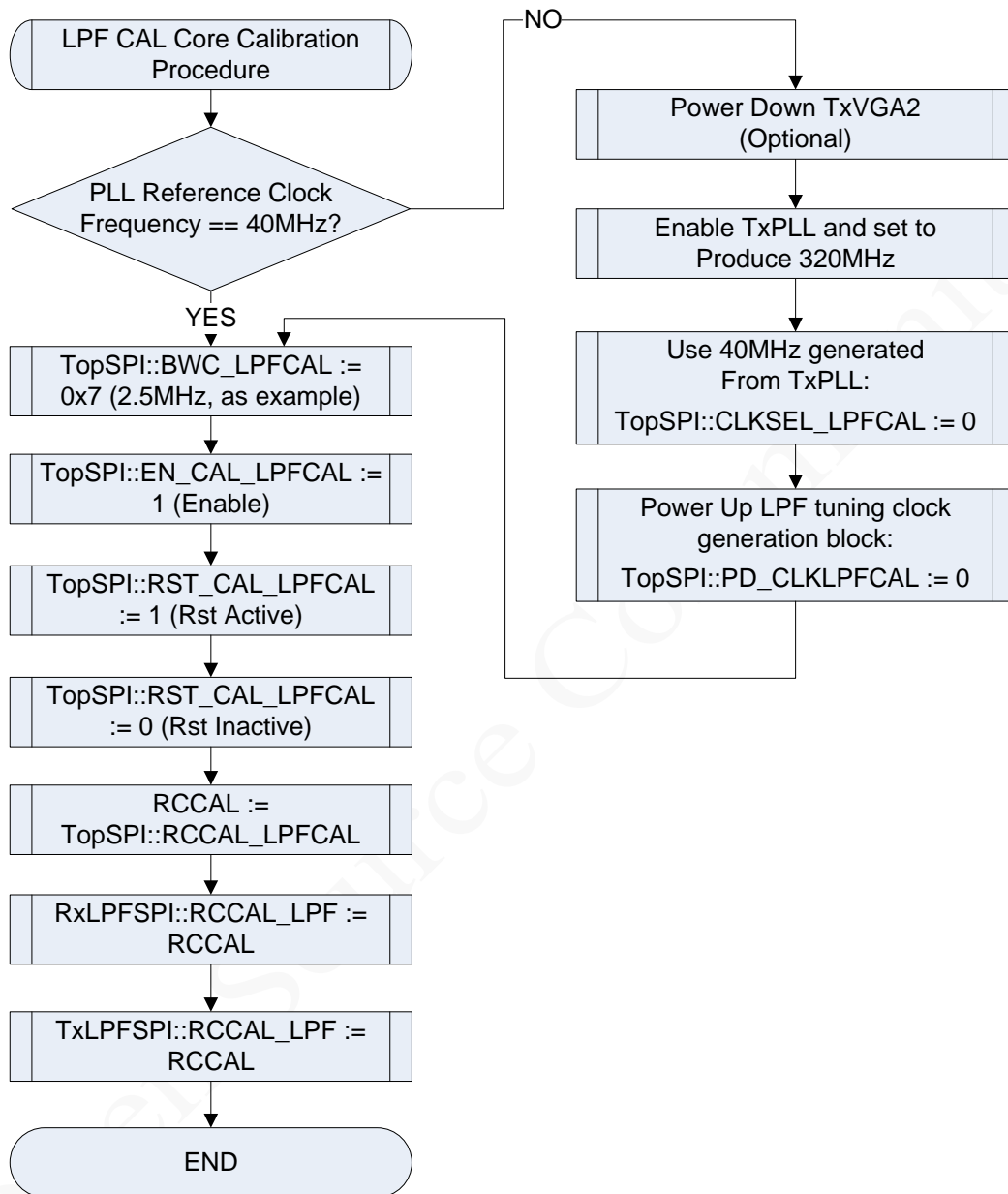

Figure 4.5

## 4.6 VCOCAP Code Selection Algorithm

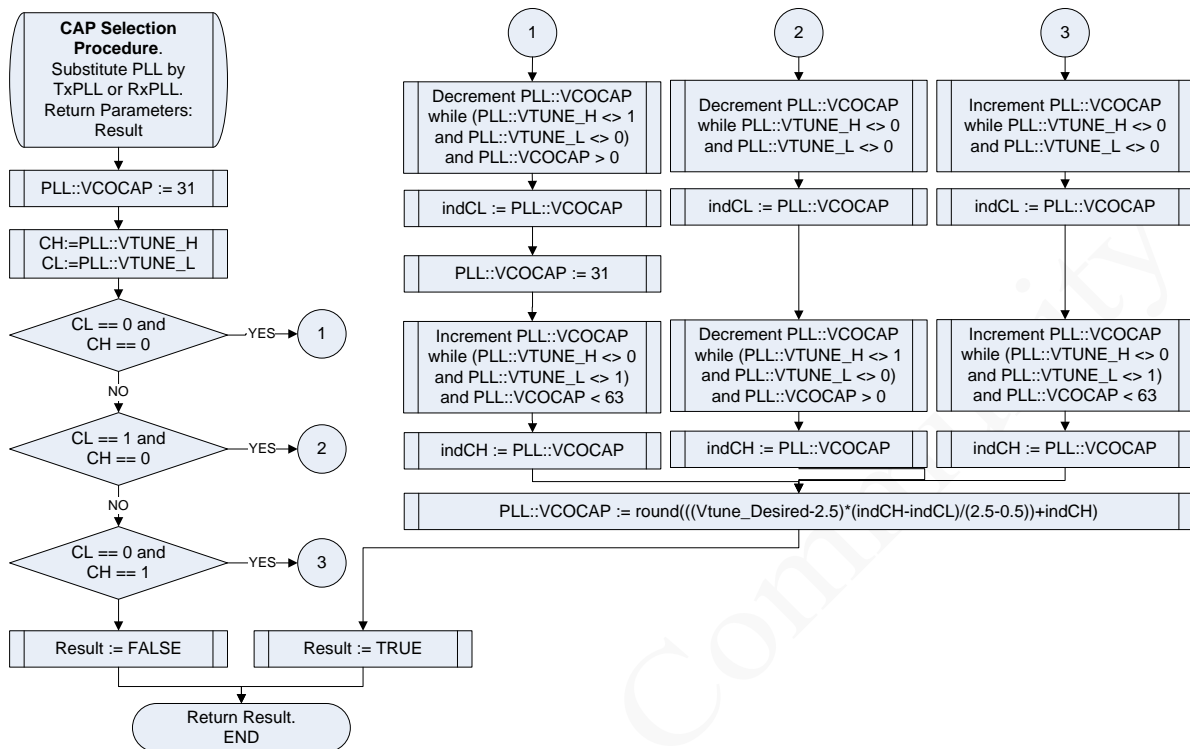

Figure 4.6

## 4.7 Auto Calibration Summary

The following is recommended auto calibration sequence.

1. DC offset cancellation of the LPF tuning module, Figure 4.2.
2. LPF bandwidth tuning, Figure 4.5.
3. DC offset cancellation of the TXLPF, Figure 4.3.
4. DC offset cancellation of the RXLPF, Figure 4.3.
5. DC offset cancellation of the RXVGA2, Figure 4.4.

Please note, while executing DC calibration procedures, no TX/RX inputs should be applied.

## 4.8 TX LO Leakage Calibration

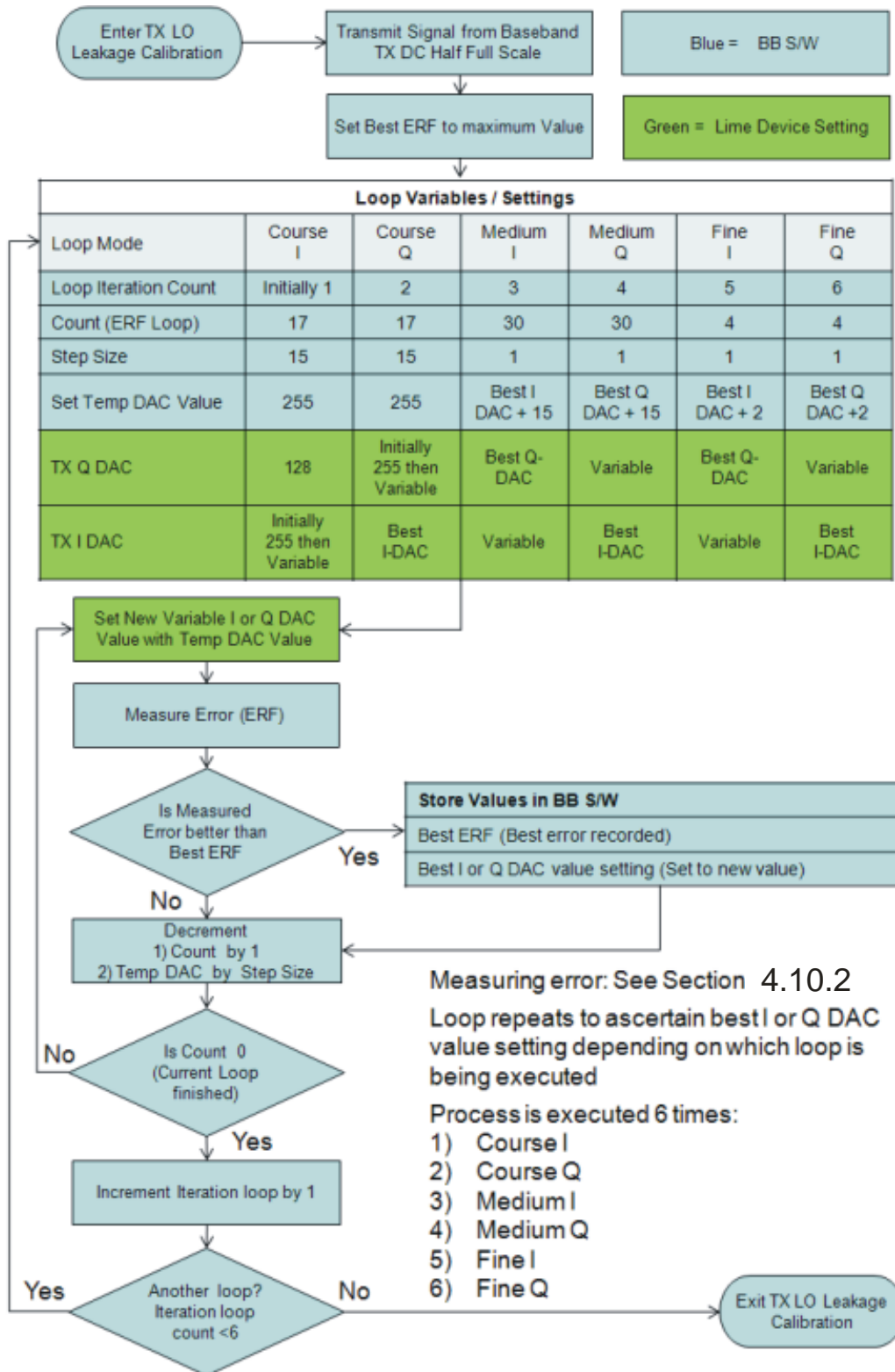

Figure 4.7

## 4.9 TX Single Side Band Calibration

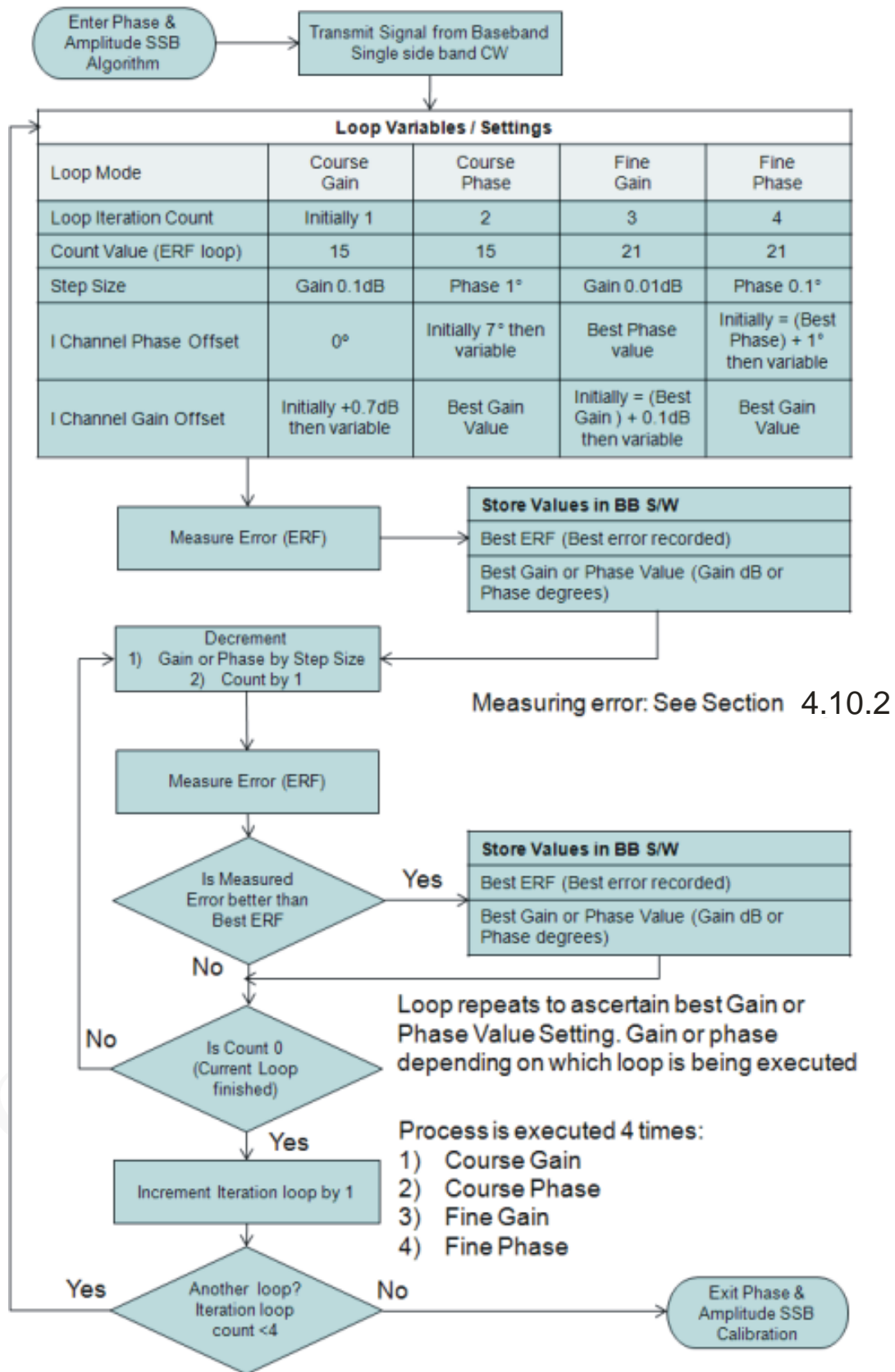

Figure 4.8

## 4.10 Correction and Measurement Functions Implemented in BB

### 4.10.1 Applying IQ Phase and Gain Offsets to Baseband Signals

Software in baseband initially applies course gain variation on the I channel and measures the loop backed signal via the LMS6002D receiver to measure the optimum value.

The baseband S/W then applies a course phase multiplier on the I channel and measures the loop backed signal via the LMS6002D receiver to measure the optimum value. The process is then repeated using a finer control step to ascertain the optimum phase and gain offset value to be applied.

The example shown in section 4.9 used the following values:

Fine or Course	Phase or Gain	Step Size	Range	Number of steps
Find Optimum Values using course steps	Gain	0.1dB	-0.7 to +0.7dB	15
	Phase	1°	+7° to -7°	15
Find Optimum Values using fine steps	Gain	0.01dB	-0.1 to +0.1dB	21
	Phase	0.1°	+1° to -1°	21

Table 4.1: SSB calibration phase and gain offset values

The methodology for applying the offsets is shown in the diagram below. The back off section is shown to illustrate how fine gain control can be applied. It is not necessary to use this in the SSB calibration routine. The optimum values recorded are then stored in baseband (fixed constant) and applied to the transmitted signal in normal operation.

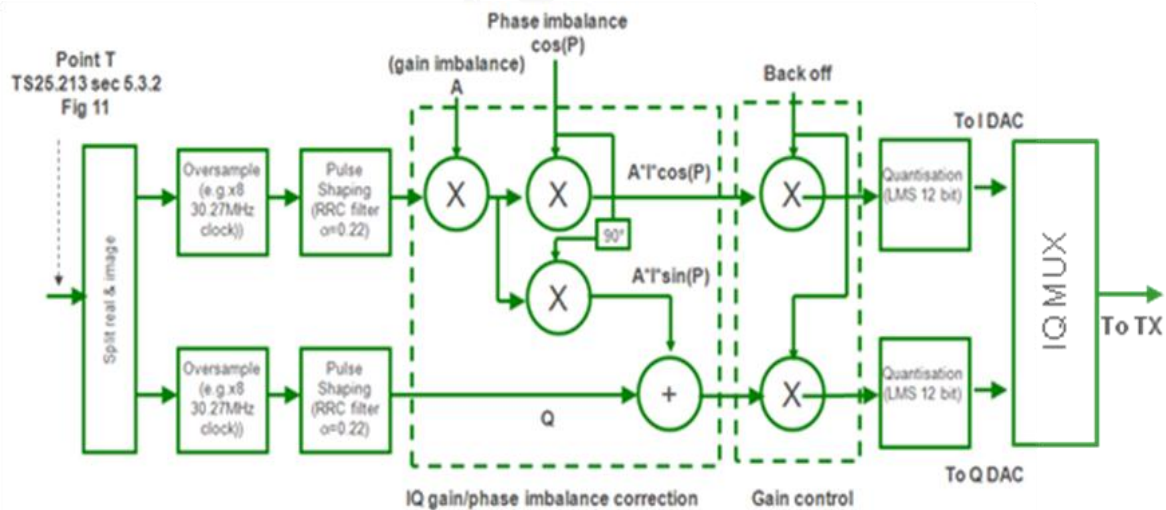

Figure 4.9: Applying I/Q gain and phase offsets to baseband transmitted signal



### 4.10.2 Measuring TX Error Using RX Signal

Software in the receiver baseband is required to measure the phase and gain imbalance between the I and Q channel received, which has been looped back from the transmitted baseband signal via the LMS6002D transceiver. The methodology of measuring the imbalance is shown in the diagram below.

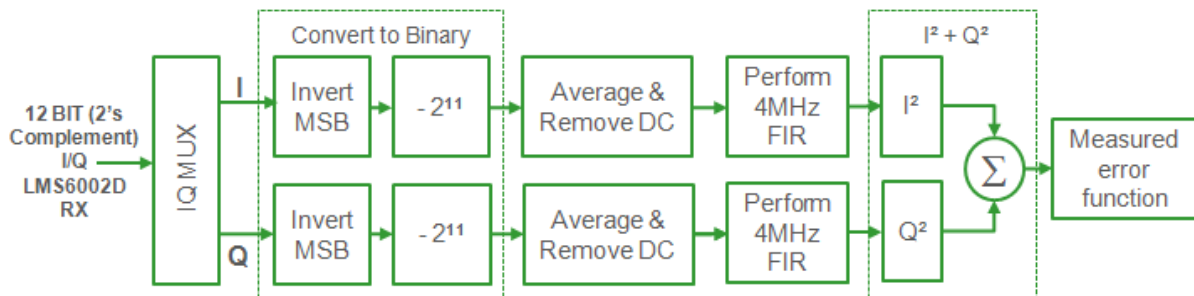

Figure 4.10: Measuring I/Q gain and phase imbalance in the baseband received signal

### 4.10.3 Measuring RX I and Q DC Levels

Software in the receiver baseband is required to measure the DC level on the I and Q channel received. The process of applying DC level adjustment to the I & Q DACS within the LMS6002 Transceiver is an optional requirement required for fine tuning purposes only. The methodology of measuring the DC levels is shown in the diagram below.

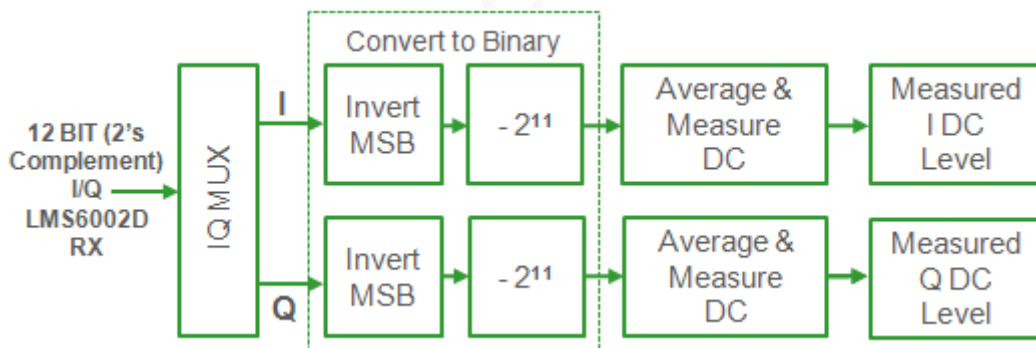

Figure 4.11: Measuring DC level on I and Q channels in the baseband received signal