

MT6235-PMU

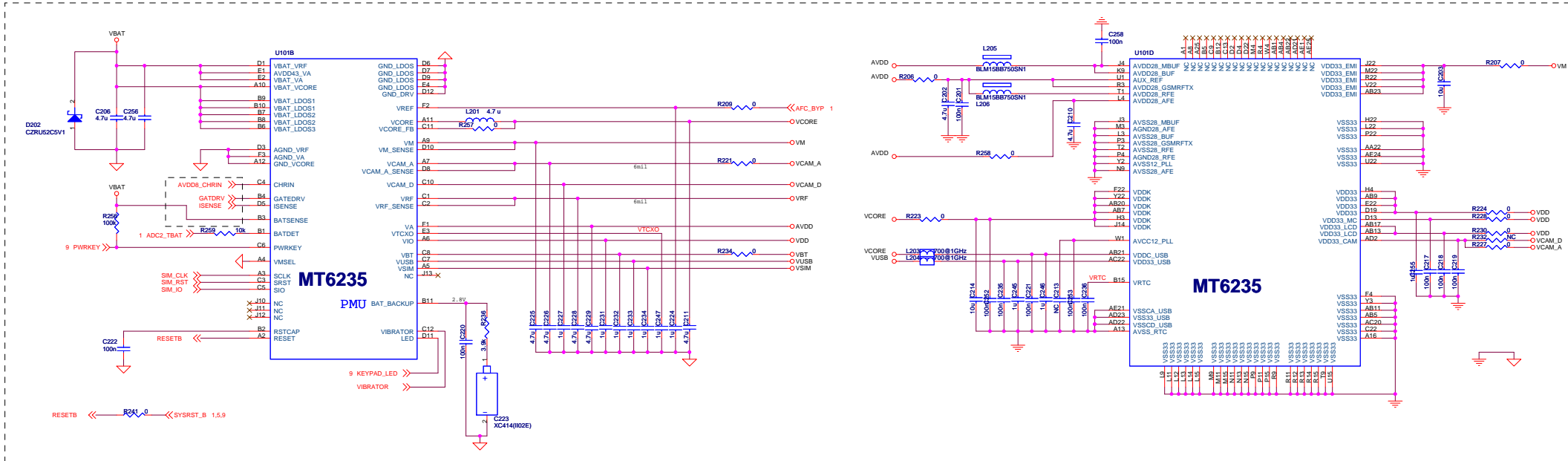

DUAL SIM I/F

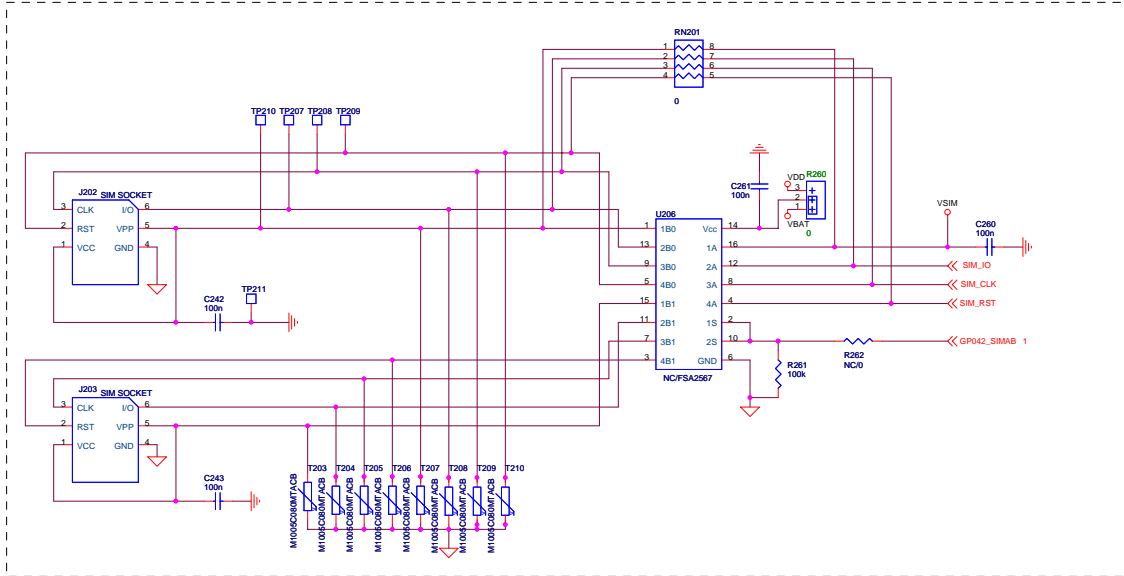

CHARGER

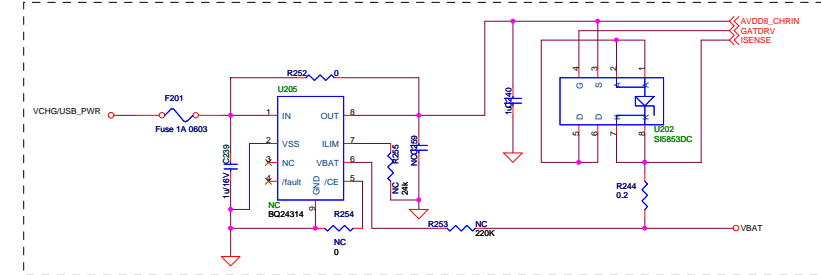

BATTERY CONNECTOR

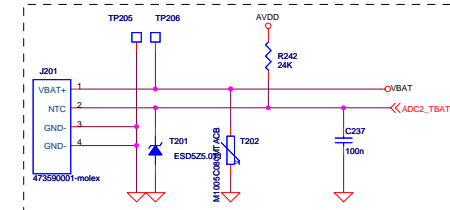

VIBRATOR

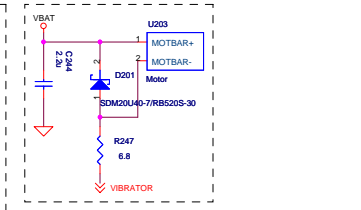

LOUD SPEAKER

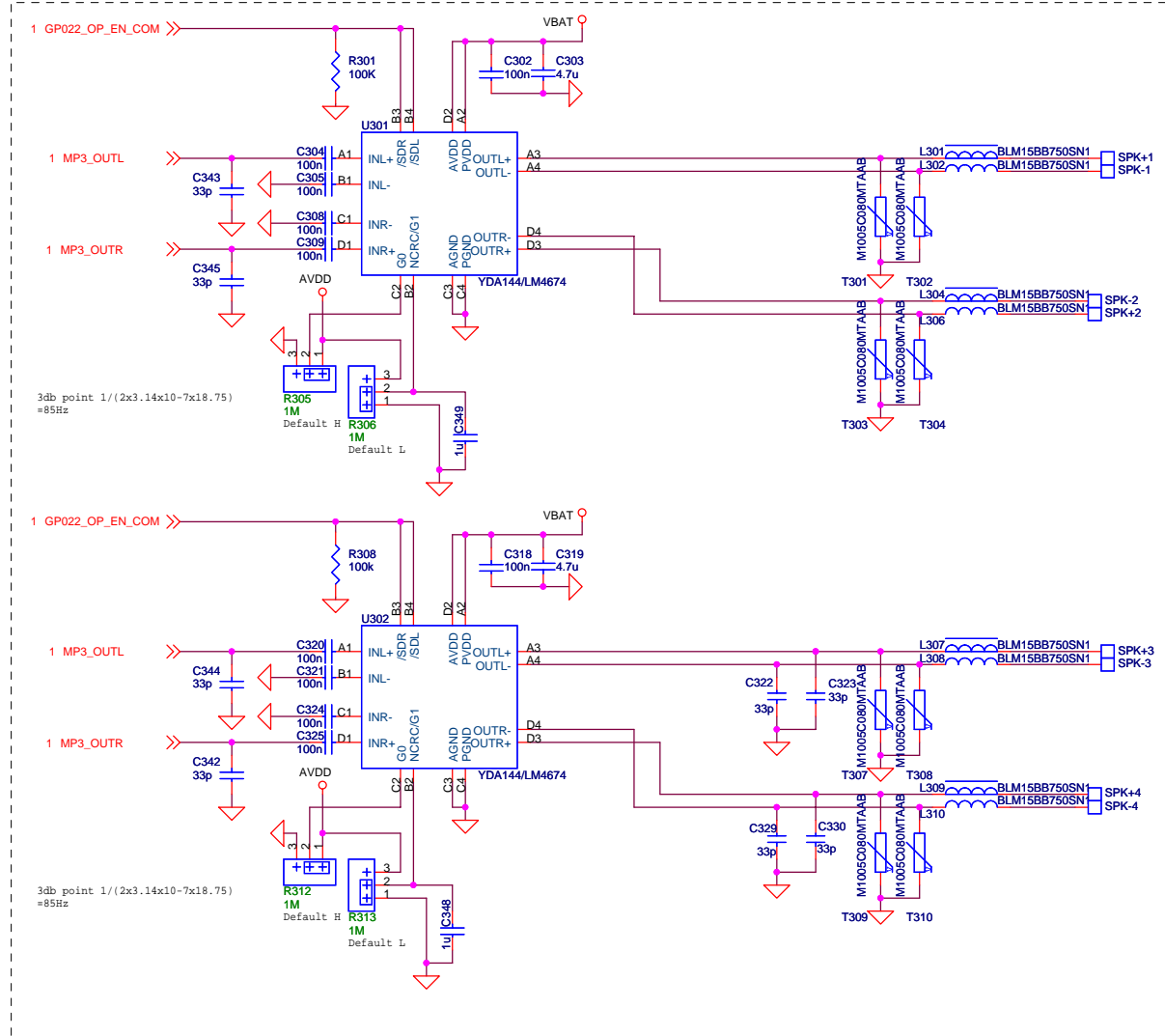

HANDSET MICPHONE

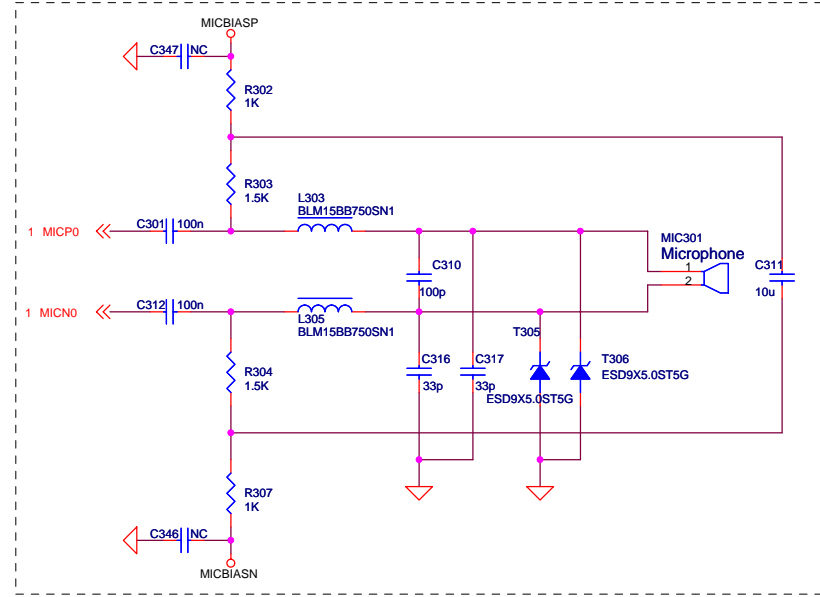

HEADSET MICPHONE

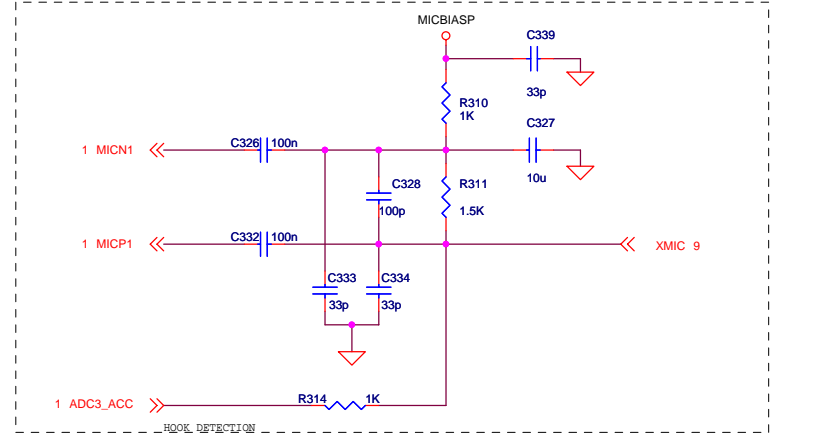

HANDSET RECEIVER

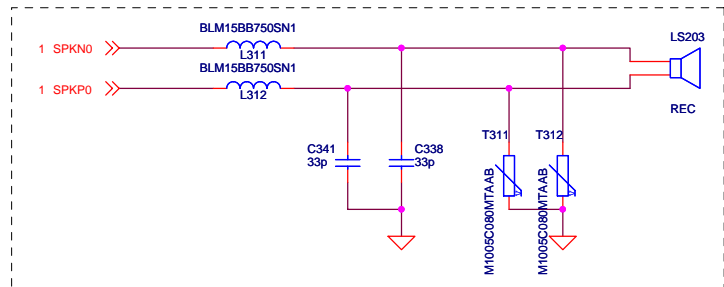

HEADSET RECEIVER

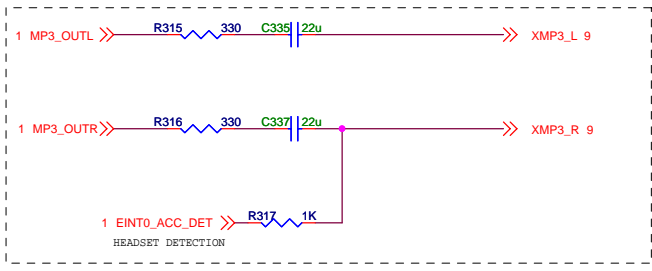

Title		
AUDIO		
Size	Document Number	Rev
A3	LIBRA35	V1.0
Date:	Monday, May 12, 2008	Sheet 3 of 9

3'' LCM CONNECTOR (DEFAULT)

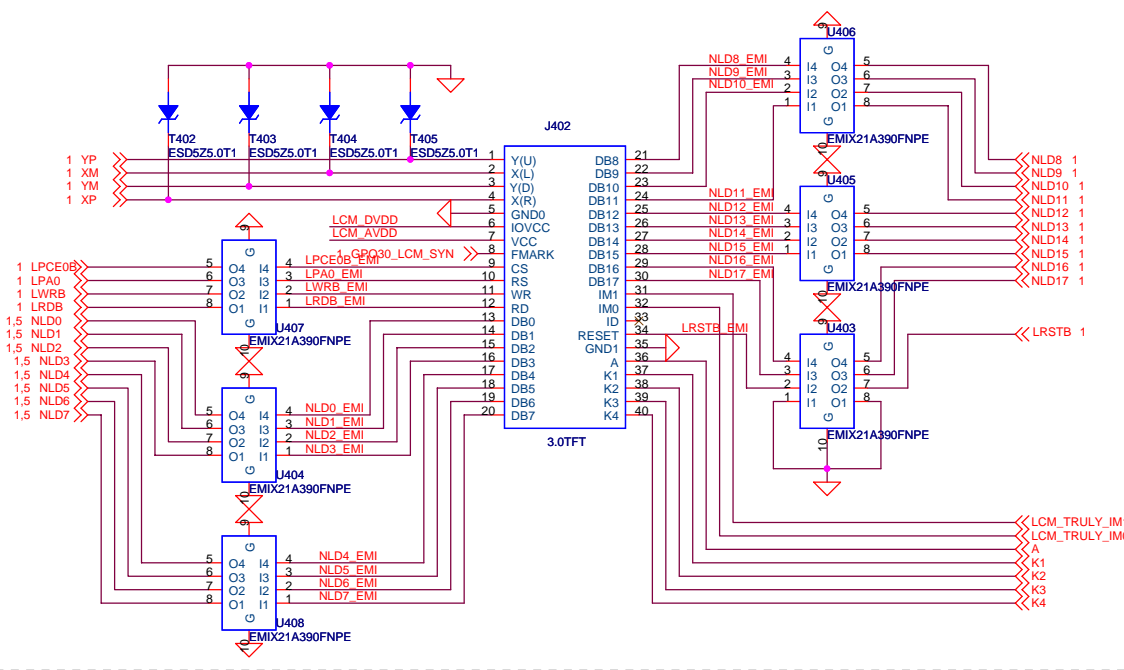

LCM BACKLIGHT DRIVER (DEFAULT)

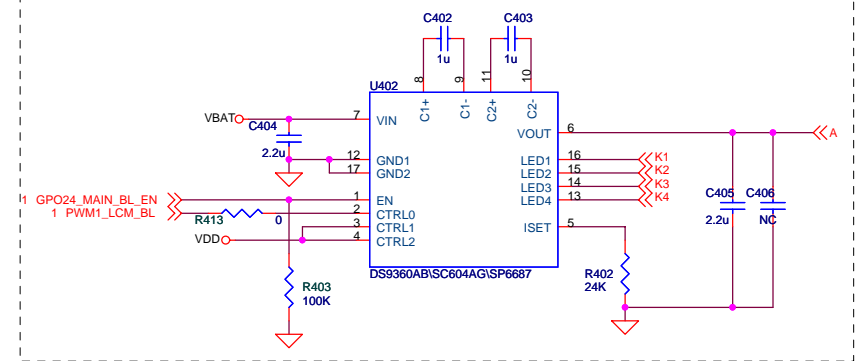

2.4'' LCM CONNECTOR

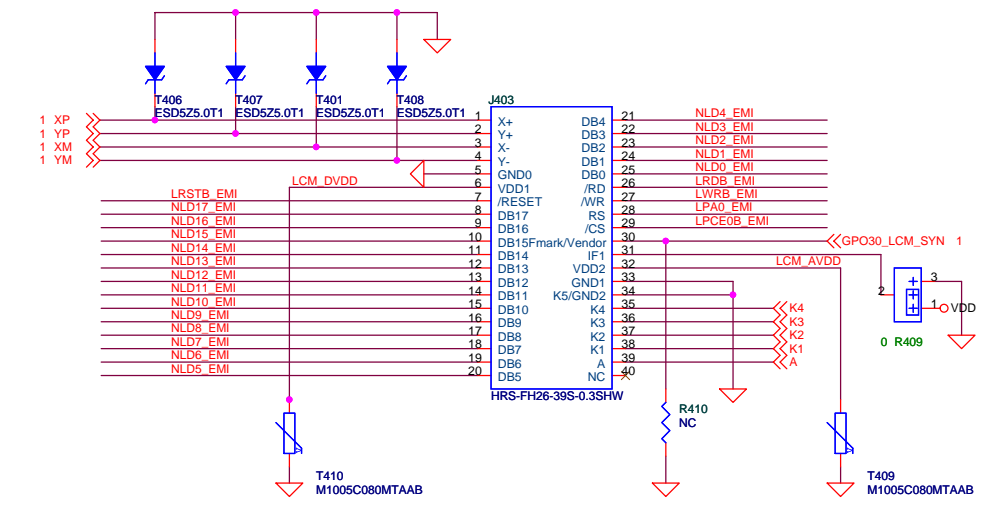

2.8'' LCM CONNECTOR

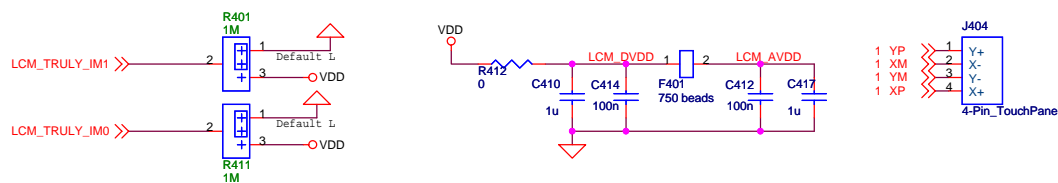
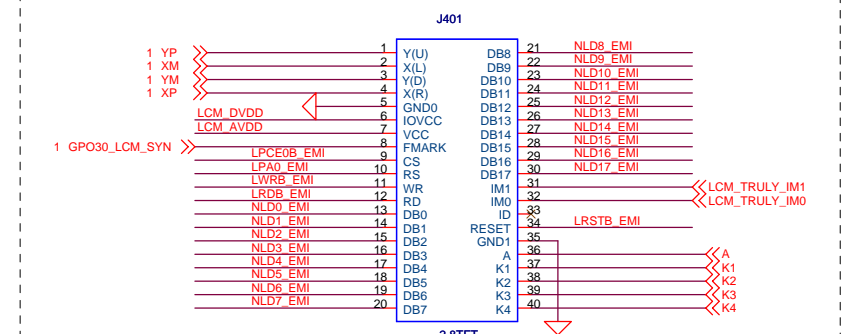

Title			LCM		
Size	Document Number		Rev		
A3	LIBRA35		V1.0		
Date:	Monday, May 12, 2008	Sheet	4	of	9

NAND+SDRAM 1G+512

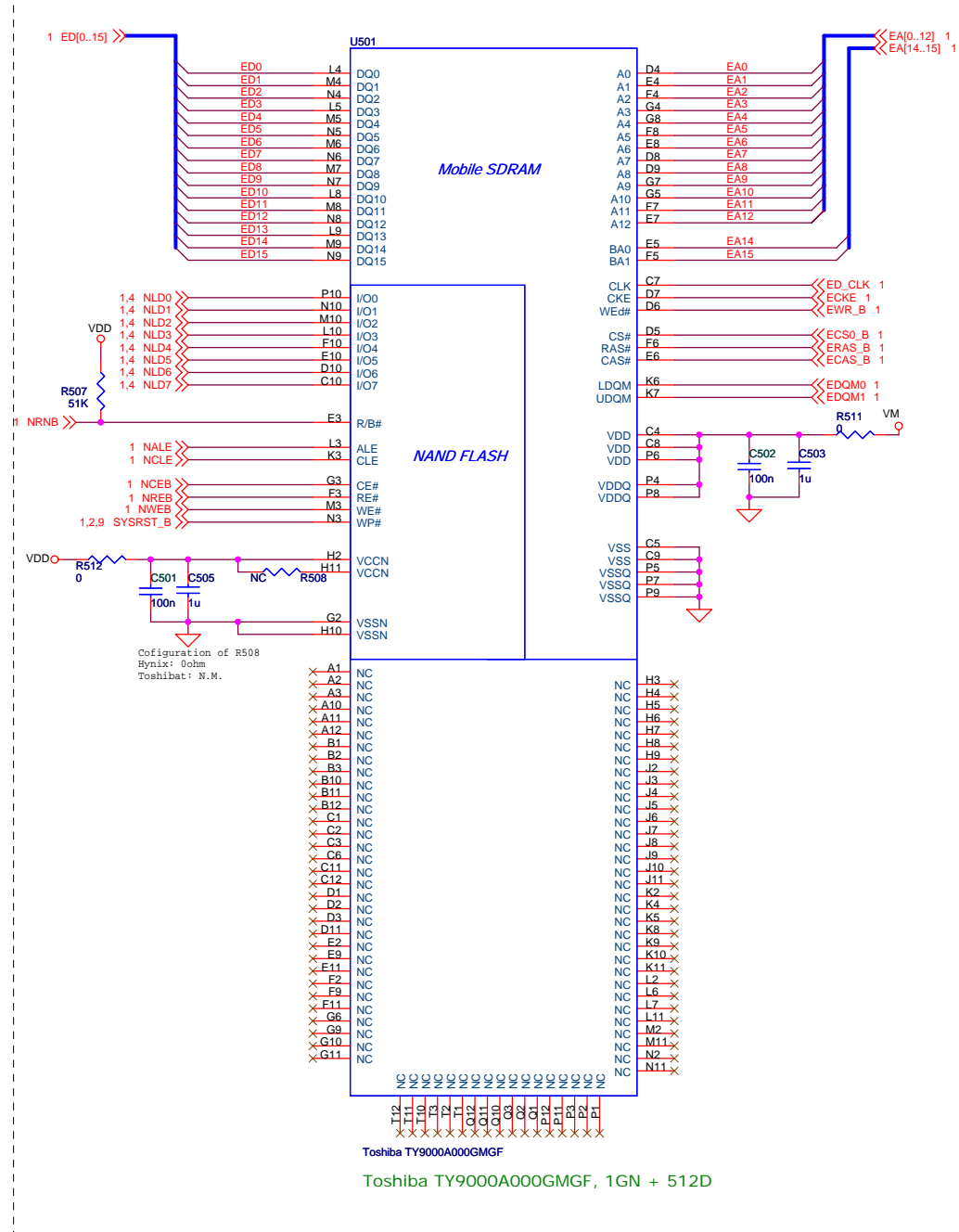

MICRO SD

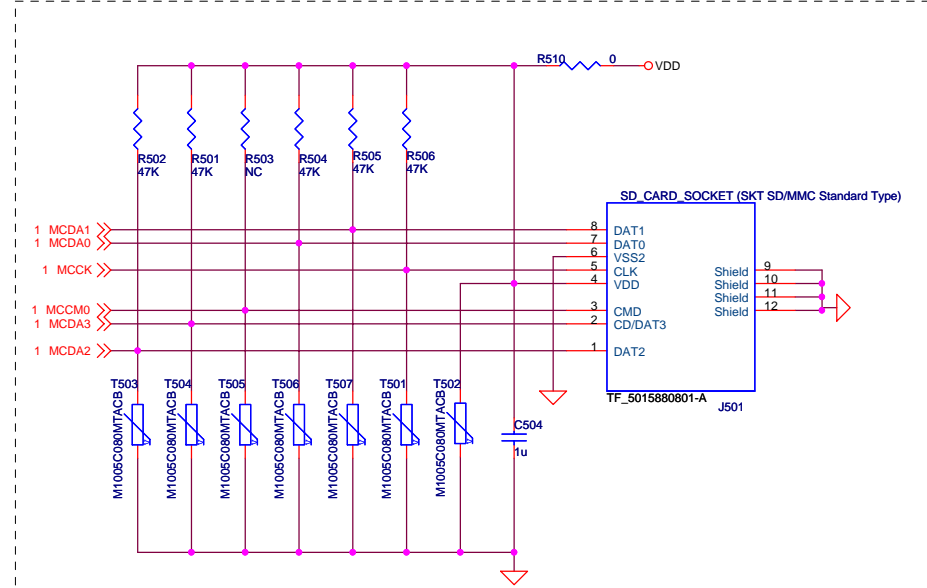

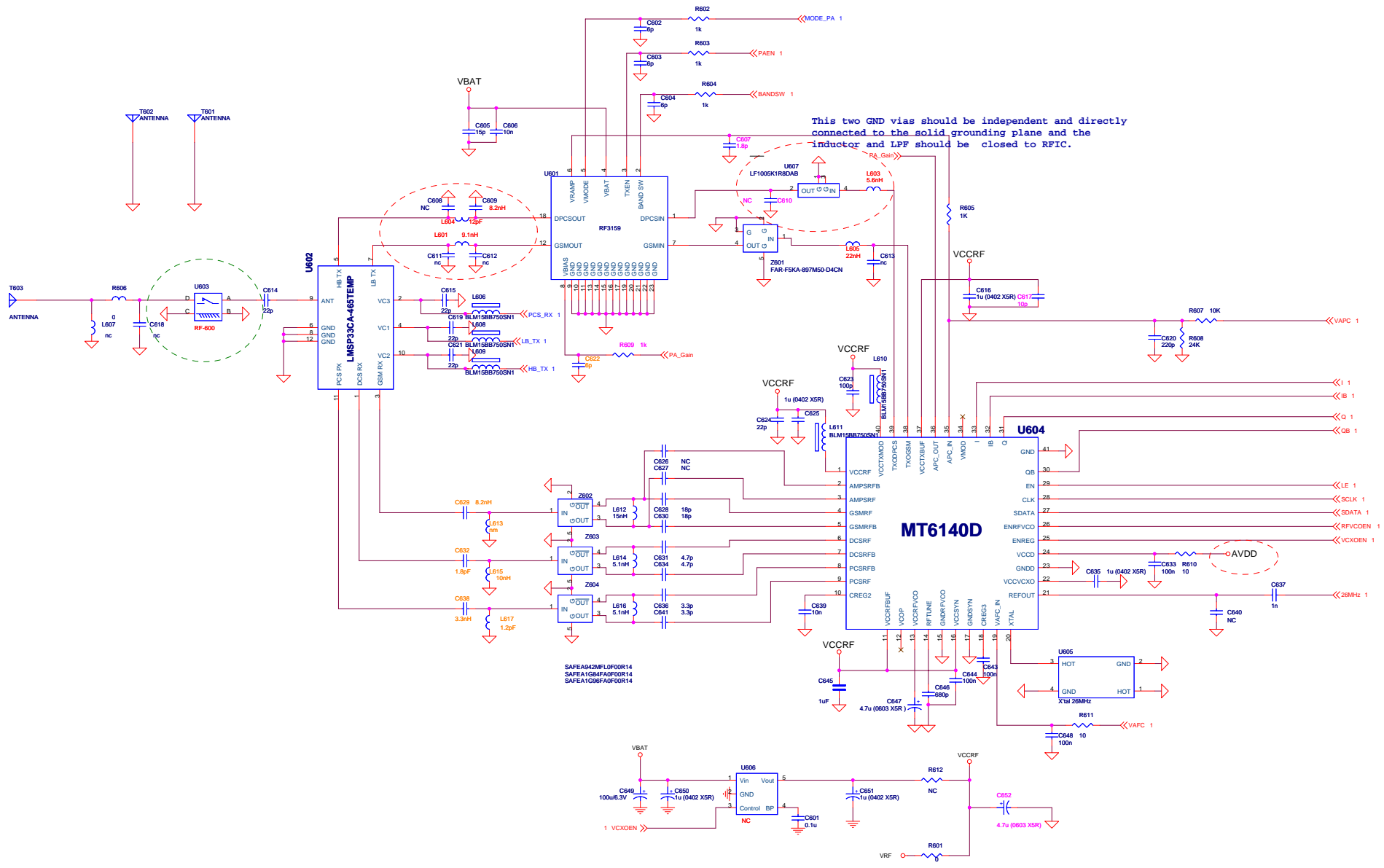

SAFEA14M2MFL0F00R14
SAFEA1G84FA0F00R14
SAFEA1G96FA0F00R14

BT

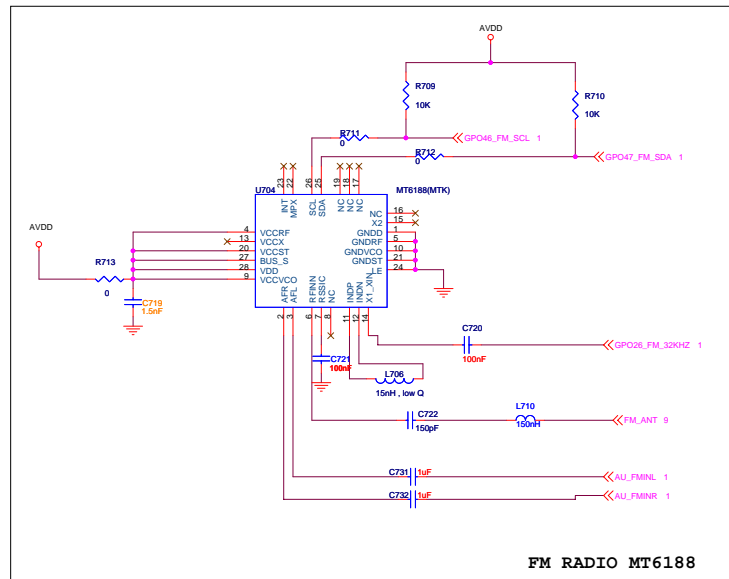
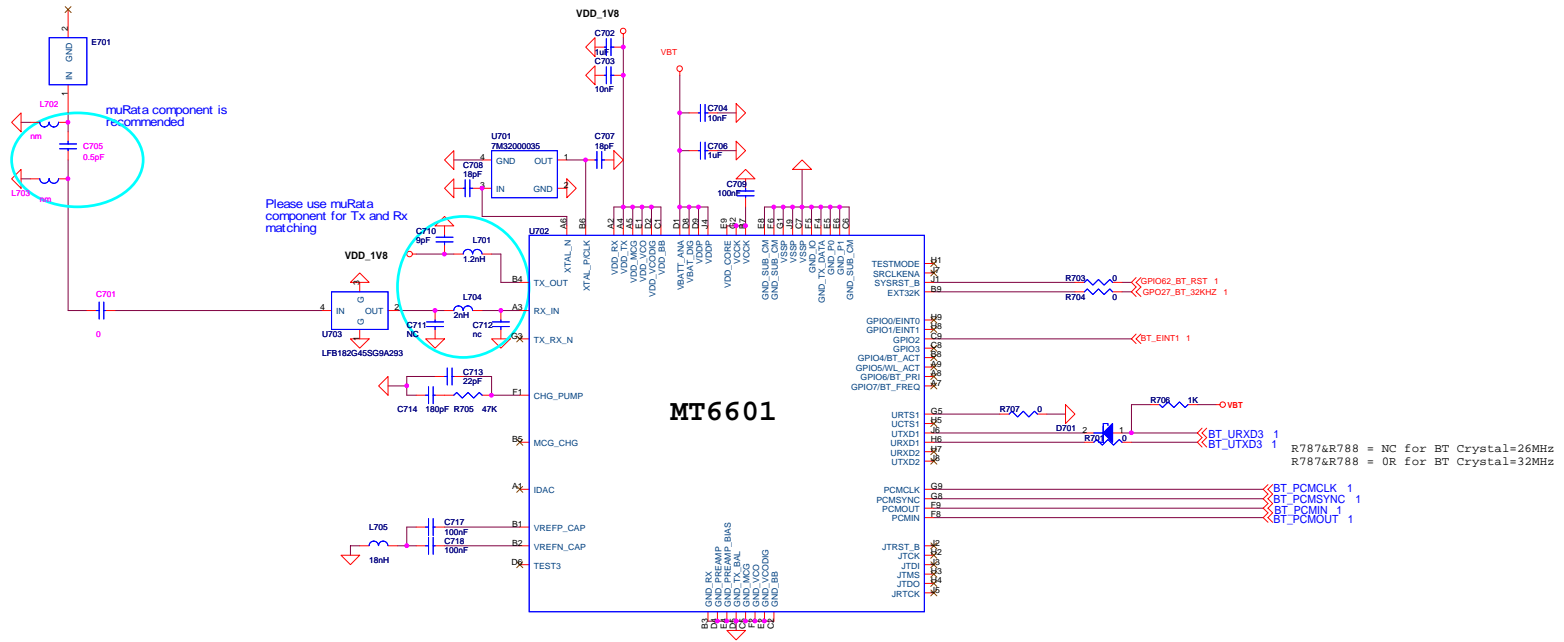

24PIN CAMERA CONNECTOR

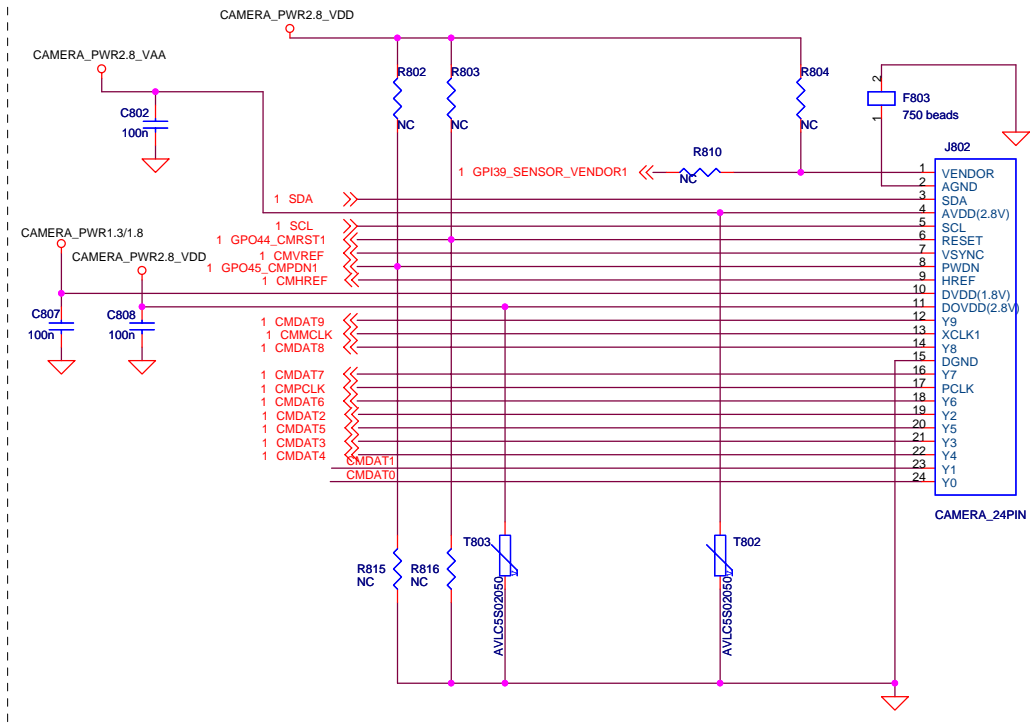

24PIN CAMERA CONNECTOR (DEFAULT)

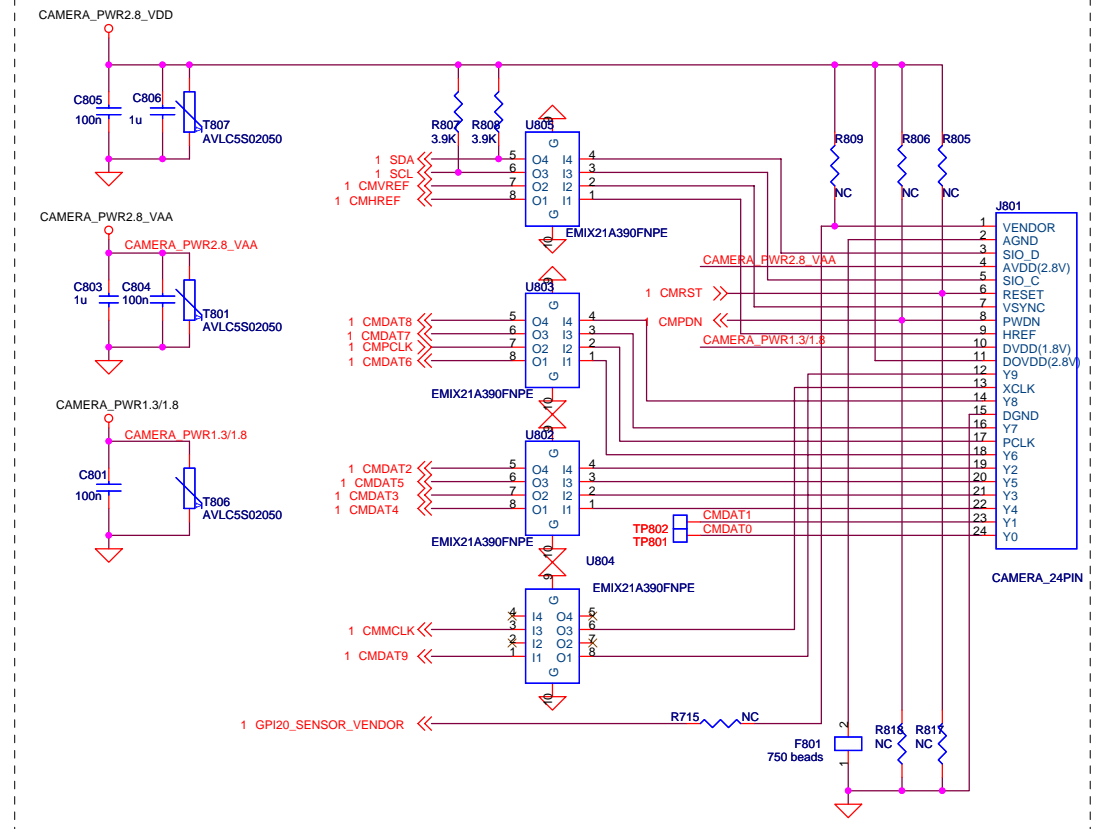

6235 DOESN'T SUPPORT DATA8 AND 9, HOW TO CONNECT THESE 2PINS?

FLASHLIGHT DRIVER

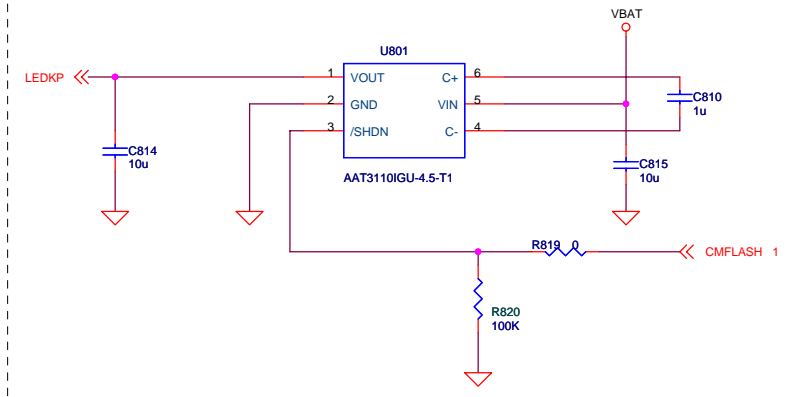

FLASHLIGHT CONNECTOR

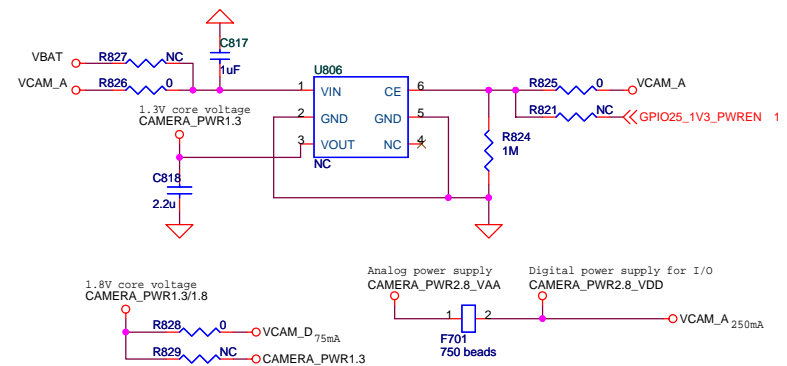
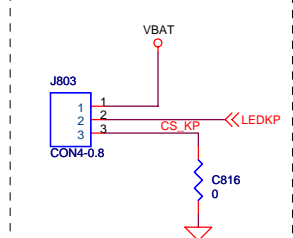

Title		
CAMERA		
Size	Document Number	Rev
A3	LIBRA35	V1.0
Date:	Monday, May 12, 2008	Sheet 8 of 9

VOL UP/ VOL DN/ SHOT/ LCD-OFF

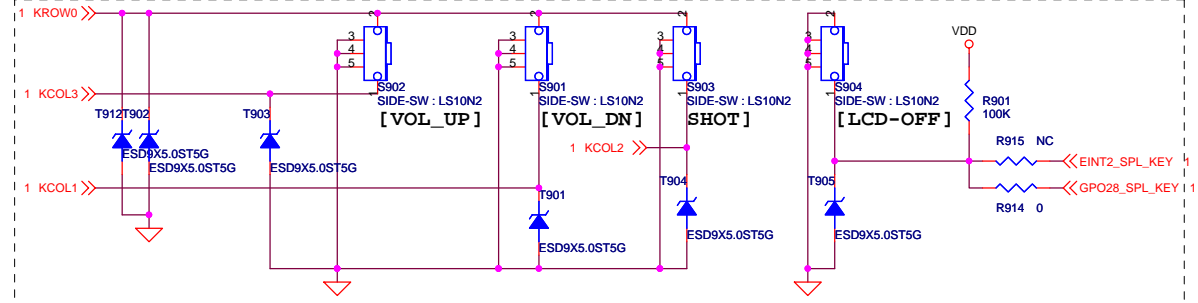

JTAG CONNECTOR

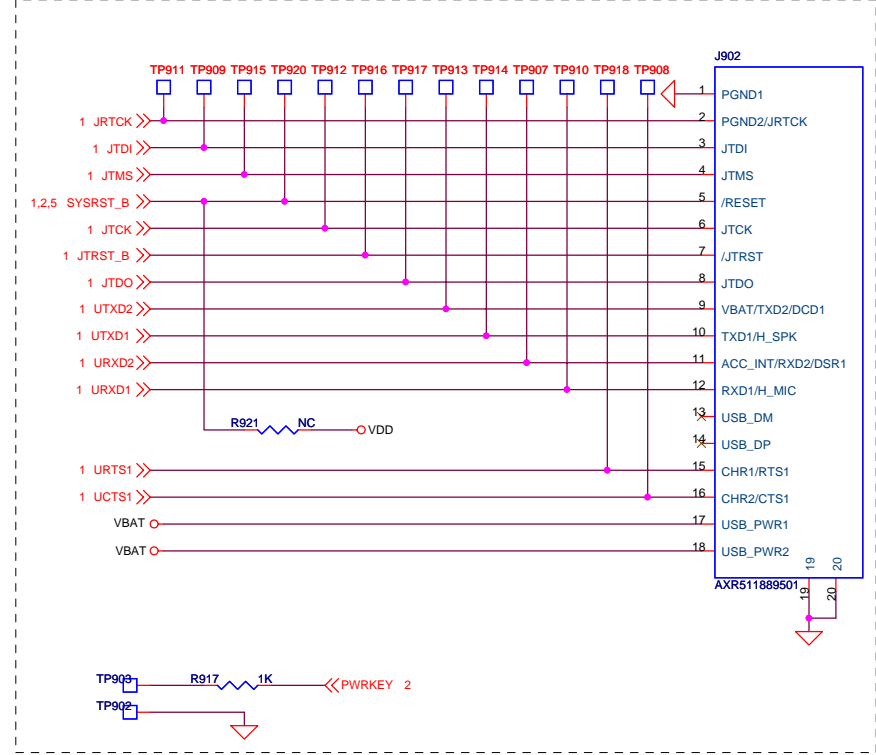

KEYPAD CONNECTOR

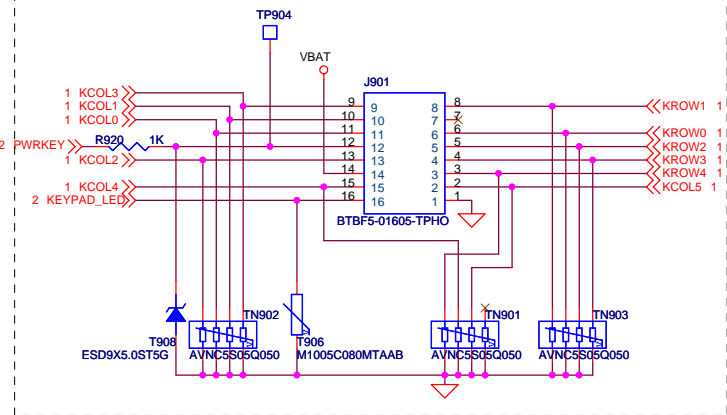

LIGHT SENSOR

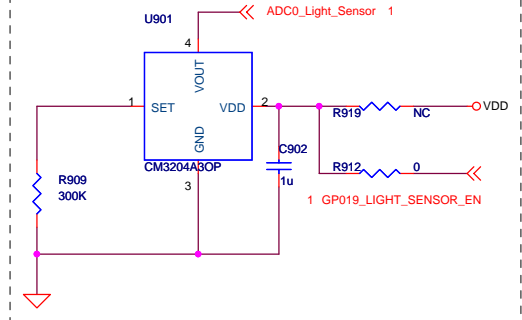

I/O CONNECTOR

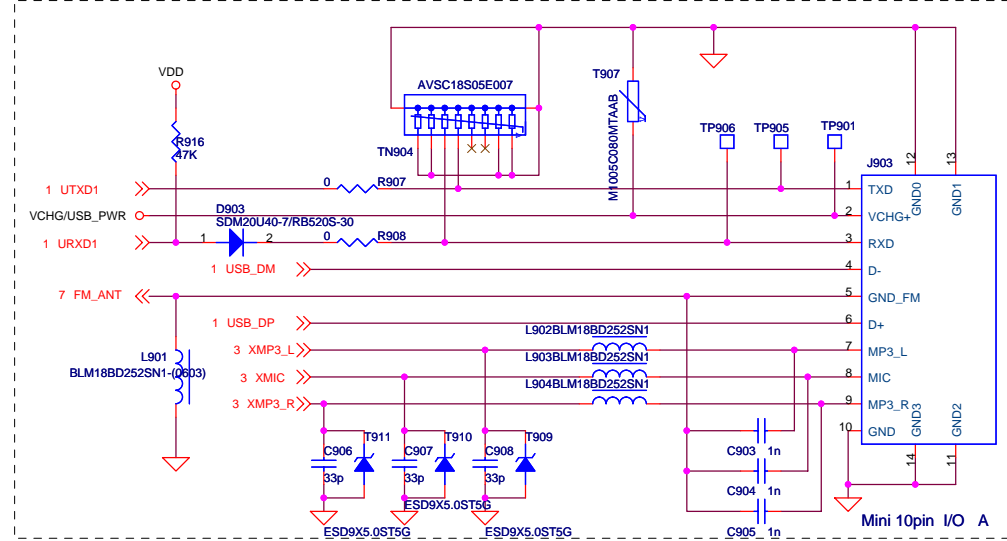

USB IF

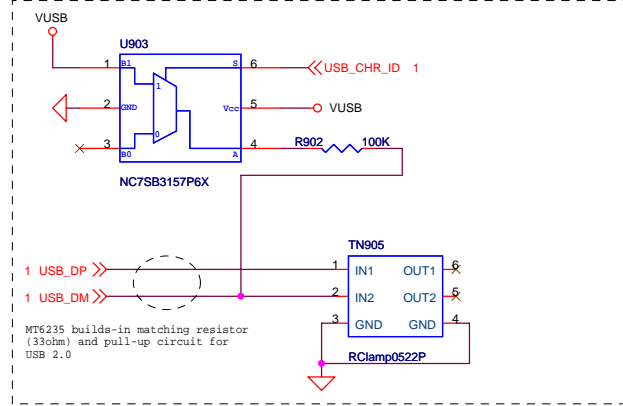

G-Sensor

